



Where Georgia comes together.

Historic Preservation Commission Agenda

Tuesday, March 14, 2023– 6:00 pm

Perry Events Center

1121 Macon Road, Perry

1. Call to Order
2. Roll Call
3. Citizens with Input
4. Announcements
 - a. Please place cell phones on silent mode.
5. Approval of the Agenda
6. Approval of Minutes – February 14, 2023, Meeting
7. Old Business
8. New Business
 - a. Update on Report of Nomination
 - b. Discuss design guidelines
9. Other Business
 - a. Commission questions or comments
10. Adjournment

All meetings of the Historic Preservation Commission are open to the public.

(478) 988-2720

<https://perry-ga.gov/historic-preservation-commission>

Historic Preservation Commission
Minutes - February 14, 2023

1. Call to Order: Chairman Moore called the meeting to order at 6:00pm.
2. Roll Call: Chairman Moore; Commissioners Beroza, Nelson, Sanders, Griffin, and Moore were present.

Staff: Bryan Wood – Community Development Director and Christine Sewell – Recording Clerk.

3. Citizens with Input – None
4. Announcements – Chairman Moore referred to the notice listed.
 - a. Please place cell phones on silent mode.
5. Approval of the Agenda

Commissioner Griffin motioned to approve the agenda as presented; Commissioner Beroza seconded; all in favor and was unanimously approved.

6. Approval of Minutes – January 24, 2023, Inaugural Meeting

Commissioner Nelson motioned to approve as submitted; Commissioner Sanders seconded; all in favor and was unanimously approved.

7. Old Business
 - a. Review and Approval of Bylaws

Commissioner Beroza motioned to approve as submitted; Commissioner Sanders seconded; all in favor and was unanimously approved.

- b. Review and Approval of Hearing Procedures

Mr. Wood advised the one change as it related to why Council was listed is the procedures were written as Council and the Commission have to hold public hearings. Chairman Moore asked for clarification on the hearing process; Mr. Wood reviewed.

Commissioner Griffin motioned to approve as submitted; Commissioner Nelson seconded; all in favor and was unanimously approved.

8. New Business
 - a. Establish boundaries for proposed district including Clinchfield, Washington, Evergreen, and Duncan area.
 - b. Determine contributing and noncontributing structures.

Mr. Wood provided a map of the current three districts initially discussed in January and for discussion to keep as currently designated or revise. Mr. Wood noted the process is to re-establish the current districts with or without modification. In discussion the Commission suggested including the nine properties on Masse Lane and Cater Avenue and create one district Washington-Evergreen. Commissioner Griffin inquired about the commercial properties being

incorporated into the downtown district. Mr. Wood noted the board of education facility can be in or out but would not have to follow guidelines due to state regulations governing school boards. Mr. Wood noted properties in the downtown area would following specific design guidelines for that district and the Commission may want to look at establishing guidelines on the type of structure. The question arose if paint color can be governed; Mr. Wood advised it could not be as the state historic commission does not allow. On conclusion of discussion, it was the consensus of the Commission to combine all districts into one which includes three non-contributing parcels and five vacant lots. Mr. Wood advised the next steps would be to prepare for the report for Dept. of Community Affairs for review which could take 30 days and then proceed with the public hearings.

With regard to non-conforming structures a Certificate of Appropriateness will have to be reviewed and there is one specifically for the historic district and downtown.

Commissioner Beroza motioned to amend the district as discussed and rename as Washington Evergreen; Commissioner Griffin seconded; all in favor was unanimously approved.

9. Other Business

- a. Commission questions or comments – None

10. Adjournment: there being no further comment to come before the Commission the meeting was adjourned at 7:05pm.



Where Georgia comes together.

Memorandum

To: Historic Preservation Commission
From: Bryan Wood, Community Development Director
Date: March 9, 2023
Re: Items for March 14, 2023, Agenda

1. Update on Report of Nomination – Staff received examples of Reports of Nomination from the State Historic Preservation Office following our last meeting. This report is more involved than we initially anticipated. We will continue to complete the draft for approval at your April meeting. We are including a digital copy of the report and will provide a paper copy at the meeting.
2. Discuss design guidelines – As we move forward with the designation process I anticipate we will receive questions about the impact to property owners. I think we should discuss design guidelines and possibly adopt those before we begin the public portion of this process. We are including a digital copy of design guidelines from Acworth and will provide a paper copy at the meeting. The Main Street Advisory Committee has adopted the commercial guidelines from this document.



Where Georgia comes together.

Community Development Department
Historic Preservation Commission

LOCAL HISTORIC PROPERTY DESIGNATION REPORT

1. Name of Property:

Washington-Evergreen Historic District

2. Boundary Description:

The Washington-Evergreen Historic District is an area of approximately 70 acres located on the southeastern edge of downtown Perry. The district consists of 112 properties which are current or former residential structures. The district is bounded generally on the East by Masee Lane, on the North by Main Street and commercial properties on Main Street, on the West by Washington Street including properties on both sides of the street, and on the South by Duncan Avenue including some properties on the south side of the street. For precise boundaries, see attached historic district map.

Perry, Georgia 31069

3. Classification:

All properties within the district are privately owned with the exception of a public park owned by the City of Perry, and a relocated historic school building owned by the Houston County Board of Education.

Number of Resources within the District:

	Non-Contributing	Contributing
Developed Parcels	5	102
Vacant Parcels	5 (including City Park)	0
Total Parcels	10	102
Primary Structures	5	102
Secondary Structures		

4. Local Certification:

As the designated authority under the City of Perry Historic Preservation Ordinance of 2022, I hereby certify that this designation report meets the documentation standards for designating properties under the Perry Historic Preservation Ordinance and meets the procedural and professional requirements set forth for such designations. In my opinion, the property meets the criteria for local designations.

Bryan Wood, AICP
City of Perry Community Development Director

Date

In my opinion, the property (___) meets (___) does not meet the criteria for local designations.

Signature of Perry Historic Preservation Commission Chair

Date

In my opinion, the property (___) meets (___) does not meet the criteria for local designations.

Signature of Mayor
City of Perry

Date

5. Function or Use:

Historic Functions:

Residential: Single-family houses

Recreation/Entertainment: Clubhouse

Current Functions:

Residential: Single-family houses

Commerce/Trade: Mortuary, professional offices, art studio, beauty salon

6. Description:

Architectural Classification:

19th Century: Victorian

20th Century: Arts and Crafts, Post WWII bungalow, Ranch

Materials:

Foundation: Brick

Walls: Brick, wood

Roof: Asphalt, metal

Description of present and historic appearance:

Summary Description of the Washington-Evergreen Historic District

The Washington-Evergreen Historic District represents one of the earliest residential areas in Perry dating to the mid- to late 1800's. The area was and continues to be home to a number of families prominent in the history and development of Perry. As population and the need to house workers increased in the early 20th century, arts and crafts bungalows were built in the area, including 12 Sears, Roebuck, & Co. kit houses. With the opening of nearby Robins Air Force Base in 1940, Perry's population more than doubled. The district includes a number of dwellings built between the early and late 1940's as WWII veterans were returning home or settling in Perry. The area continued to develop over the late 20th century and early 21st century.

Historic Integrity of the Washington-Evergreen Historic District

Demolition, alteration, and new construction has had limited impact on the historic integrity of the built resources within the Washington-Evergreen Historic District. The areas historic fabric remains intact and continues to convey a strong sense of the past. The street and block pattern reflects the original layout of the are based on topography. Most buildings in the district are well maintained and express a substantial degree of historic integrity.

The following information is provided for each resource in the Washington-Evergreen Historic District:

Property address	Contributing/Non-Contributing determination
Tax Parcel Number	
Georgia Historic Resource Number	
• Historic Name/Common or current name (if known)	
• Date of construction	
• Comments	
[The following is provided for contributing buildings only]	
• Style/building type	
• Key contributing design elements	
• Significant alterations/non-contributing elements	

702 Washington Street
0P0030 026000
HT-P-118

Contributing



/McLain House
1948
Minimal Traditional

705 Washington Street
OP0040 058000
HT-P-119

Contributing



/Bishop House
1920
No Academic Style

708 Washington Street
OP0030 025000
HT-P-116

Contributing



/Zammit House
1913
No Academic Style

711 Washington Street
OP0040 58A000
HT-P-117

Contributing



/Zammit House
1920
No Academic Style

713 Washington Street
OP0040 053000
HT-P-115

Contributing



/Smith House
1925
No Academic Style

802 Washington Street
OP0030 024000
HT-P-113

Contributing



Judge Clinton C. Duncan House/Pullen House
1835; Second story addition in 1877
Folk Victorian
Carport added in 1983



Charles Harris House/Rabun House
1930
English Vernacular Revival



/Overton House
1925
Craftsman
Vinyl siding, rear addition



Charles & Cinderella Cooper House/Lay House
1880
American Queen Anne/Stick
Outbuilding believed to be original stables



807 Washington Street Secondary Structure





Fletcher Cater House/Gilmour House
1875
Folk Victorian



Miller House/Sanders House
1854
American Queen Anne



/Whitaker House

1940

English Vernacular Revival/Colonial Revival

Vinyl siding, enclosed front porch



Annie Meadows House/Kakapo House

1942

No Academic Style

Vinyl siding, replacement window, porch railing, (missing original porch roof?)



J. G. Vissher House/Crossley House
1855
American Queen Anne
Rear addition

901 Washington Street
OP0040 036000
HT-P-101

Contributing



Perry Methodist Church Parsonage/Holloway House
1915



Evelyn Whipple House/Edwards House
1927
Colonial Revival



Evans House/Tuggle House
1941
Colonial Revival



Lucille Kezar Cooper House/O'Neal House
1920
Craftsman
Perry's first brick house

905 Washington Street
OP0040 038000
HT-P-0099

Contributing



/Kelley House
1880
Carpenter Italianate



/Hull House
1920
No Academic Style
Rear addition

907 Washington Street
0P0040 039000
HT-P-098

Contributing



H. P. Houser House/Golden House
1890
Craftsman



Hoton-Skellie-Houser House/
1850; Moved from Evergreen Street in 1986
No Academic Style

1004 Gilmer Street
OP0030 041000
HT-P-154

Contributing



Irby House
1944
No Academic Style

1005 A Gilmer Street
OP0030 007000
HT-P-153

Contributing



Herndon House/
1949
No Academic Style
Replacement windows, metal roof, aluminum siding



Herndon House/Murray House
1981

1006 Gilmer Street
OP0030 040000
HT-P-155

Contributing



/Sayer House
1940
Colonial Revival



O'Neal House/Witherington House
1959



Kate Houser House/Murray House
1952



O'Neal House
2003

1101 Beckham Circle
OP0030 053000
HT-P-156

Contributing



Pritchett House/Beckham House
1935
Colonial Revival

1102 Beckham Circle
OP0030 079000
HT-P-157

Contributing



Powers-Beckham House/Beckham House
1870; Moved from Main Street to current location in 1924
Sunporch and Porte Cochere added in 1924
Greek Revival/Neoclassical Revival



1104 Beckham Circle
0P0030 078000

Contributing

Beckham House/George Nunn Jr. House
1960

1105 Beckham Circle
OP0030 054000
HT-P-158

Contributing



Sam Nunn Sr. House/Pyles House
1937
English Vernacular Revival/Colonial Revival/Minimal Traditional
Childhood home of U. S. Senator Sam Nunn

1204 Beckham Circle
0P0030 087000
HT-P-161

Contributing

Lewis House/Kyle House
1950
Colonial Revival

1205 Beckham Circle
0P0030 062000

Non-Contributing

Moore House
1986

1208 Beckham Circle
0P0030 086000
HT-P-162

Contributing

/Newby House

1900; moved from Main Street in the 1960's, covered front porch removed
American Queen Anne

1302 Beckham Circle
0P0030 085000

Non-Contributing

Katsekis House
2005

901 Clinchfield Circle
OP0100 009000
HT-P-163

Contributing

/Mims House
1925
No Academic Style

909 Masee Lane
0P0100 007000

Contributing

Mann House/Alridge House
1954

905 Beckham Circle
0P0030 065000

Contributing

Springhill School/Educational Events
1905

902 Beckham Circle (School Street)

0P0030 077000

HT-P-159

Contributing

Eugene Beckham House

1929

Colonial Revival/Minimal Traditional

900 Beckham Circle (School Street)

OP0030 060000

HT-P-160

Contributing

/Johnson House

1940

English Vernacular Revival

904 Duncan Avenue
0P0110 003000
HT-P-120

Contributing

Edward L. Felder House/
1870
Craftsman
Front porch enclosed, roof pitch increased, dormer added

**1001 Duncan Avenue
0P0030 027000
HT-P-121**

Contributing

**Mosteller House
1948
Colonial Revival**

**1004 Duncan Avenue
0P0110 024000
HT-P-123**

Contributing

**/Russell House
1944
Minimal Traditional**

**1005 Duncan Avenue
0P0030 028000
HT-P-122**

Contributing

**/Gentry House
1946
Minimal Traditional**

**1006 Duncan Avenue
0P0110 023000
HT-P-124**

Contributing

**/Layson House
1943
Minimal Traditional**

**1007 Duncan Avenue
0P0030 029000
HT-P-125**

Contributing

**/Perkins House
1946
Minimal Traditional**

**1008 Duncan Avenue
0P0110 022000
HT-P-127**

Contributing

**/Kersey House
1943
Minimal Traditional**

**1009 Duncan Avenue
0P0030 030000
HT-P-126**

Contributing

**/Mygrant House
1943
Minimal Traditional**

**1010 Duncan Avenue
0P0110 021000
HT-P-128**

Contributing

**/Griner House
1943
Minimal Traditional**

**1011 Duncan Avenue
0P0030 031000
HT-P-129**

Contributing

**Chapman House/Bankston House
1946
Minimal Traditional**

**1012 Duncan Avenue
0P0110 020000
HT-P-131**

Contributing

**/Russell House
1943
Minimal Traditional**

**1013 Duncan Avenue
0P0030 032000
HT-P-130**

Contributing

**Brooks House
1945
Minimal Traditional**

**1015 Duncan Avenue
0P0030 42A000**

Contributing

**/Avila House
1930**

**1017 Duncan Avenue
0P0030 043000**

Contributing

**Johnson House/Wood House
1963**

**1018 Duncan Avenue
0P0110 015000**

Contributing

**Chitty House/Canas House
1951**

**1020 Duncan Avenue
0P0110 014000
HT-P-132**

Contributing

**Lasseter House/Cravey House
1950
No Academic Style**

**1103 Duncan Avenue
0P0030 091000**

Contributing

**Pierce House/Fryer House
1964**

**1005 Duncan Avenue
0P0030 91A000**

Contributing

**Pierce House/Dunaway House
1950**

707 Masee Lane
0P0030 092000

Contributing

Watson House/Kamerer House
1951

703 Tolleson Avenue
0P0030 33A000

Contributing



Medlock House/Gordon House
1968

704 Tolleson Avenue
OP0030 052000
HT-P-133

Contributing



/Polston House
1947
No Academic Style
Vinyl siding



Weems House/Whiting House
1958

Detached outbuilding, replacement windows, vinyl siding on gable ends, attached carport enclosed as garage

706 Tolleson Avenue
0P0030 051000
HT-P-134

Contributing



/Anderson House
1946
No Academic Style
Rear addition
Vinyl siding

1004 Cater Avenue
OP0030 050000
HT-P-135

Contributing



/Surber House

1940

Colonial Revival

Detached outbuilding

Vinyl siding, replacement windows



Rogers House/Bryant House

1947

Minimal Traditional

Side Addition, Detached garage/outbuilding



Rape House/Lawless House

1946

Minimal Traditional

Side addition, attached carport, replacement windows, aluminum siding on gable ends, aluminum porch cover

**1105 Cater Avenue
0P0030 082000**

Contributing

**Mason House/Walker House
1948**

**1106 Cater Avenue
0P0030 088000
HT-P-165**

Contributing

**/Brittle House
1947
Neoclassical Revival**

**1107 Cater Avenue
0P0030 083000**

Contributing

**/Simpson House
1949**

**1111 Cater Avenue
0P0030 084000**

Contributing

**Grant House/Amrit House
1952**

**701 Evergreen Street
0P0030 044000
HT-P-137**

Contributing

**Bozeman House/Lonergan House
1955
Colonial Revival**

**703 Evergreen Street
0P0030 046000
HT-P-138**

Contributing

**Marshall House/Nelson House
1941
No Academic Style**

**704 Evergreen Street
0P0030 090000**

Contributing

**Whipple House/Austin House
1951**

**705 Evergreen Street
0P0030 047000
HT-P-139**

Contributing

**/Polston House
1939
Colonial Revival
Shed carport addition**

**706 Evergreen Street
0P0030 089000**

Contributing

**Brown House/Rogers House
1948**

**709 Evergreen Street
0P0030 048000**

Contributing

**/Yasin House
1941**

**800 Evergreen Street
OP0030 081000
HT-P-140**

Contributing



**Cecil Moody House/Walker House
1951
English Vernacular Revival/Minimal Traditional
Garage and utility building constructed in 2009**

**802 Evergreen Street
0P0030 080000**

Contributing

**Allen Pritchett House/Childers House
1961**

**803 Evergreen Street
0P0030 035000
HT-P-141**

Contributing

**Coralie Brown Nunn House/Houser House
1951
Minimal Traditiona**

**805 Evergreen Street
0P0030 037000
HT-P-142**

Contributing

**Middlebrooks House
1942
Colonial Revival
Detached garage added in 1978**

**807 Evergreen Street
0P0030 038000
HT-P-143**

Contributing

**Mrs. F. M. Houser House/Scott House
1940
Colonial Revival
Garage and other additions on the rear of the house**

809 Evergreen Street
OP0030 039000
HT-P-144

Contributing



Davis-Sexton House/Cosey House
1939
Colonial Revival
Garage and other additions to the rear of the house

901 Evergreen Street
OP0030 010000
HT-P-145

Contributing



John Hodges House/Amrit House
1941
Colonial Revival
Detached carport added 2017



902 Evergreen Street
OP0030 059000
HT-P-147

Contributing



First Baptist Church Pastorium/McComb House
1910
American Queen Anne



John Hicks Hodges House/Patel House
1894
American Queen Anne
Utility building constructed in 1976



904 Evergreen Street
OP0030 058000
HT-P-148

Contributing



Mrs. Jule Hurst House/Walker House
1913
Craftsman
Enclosed side porch

905 Evergreen Street
0P0030 012000

Non-Contributing

Day care/Perry Head Start
1981

906 Evergreen Street
OP0030 057000
HT-P-149

Contributing



Pringle House/James House

1880

Folk Victorian

Addition to rear of house; Detached carport in 1992

907 Evergreen Street
0P0030 013000

Non-Contributing

Vacant Lot

911 Evergreen Street
OP0030 014000
HT-P-150

Contributing



Anderson House/rental
c. 1900
Folk Victorian
Altered window size, vinyl siding

913 Evergreen Street
OP0030 015000
HT-P-151

Contributing



James M. Gooden House/Russell House
1926
Craftsman



LARGE HOME FOR SALE

Located on **Evergreen** St. 1 Block from town, and 3 churches. Right across from School. 2,000 sq. feet in home, and heart pine wood. 1st floor: 3 bedrooms, den, kitchen, breakfast room, front porch, back porch, and bath. Natural upstairs that could be finished.

Reasonable price, and terms. Call ALLEN P. WHIPPLE for appointment to see this nice home.



Samuel D. Killen House/Watson Hunt Mortuary
1852

Greek Revival/Neoclassical Revival

In the 1920's the house was used as a clubhouse of visiting officials of the Clinchfield Portland Cement Corporation, later Pennsylvania Dixie Cement Corporation.

Front porch altered, wings added and expanded, garage added in 1983



Residence of Mrs. Francis Marion King, Organizer of U.D.C. Chapter Ga. Div., Perry, Ga.



Dr. Henry Holtzclaw House/Town and Country Realty
1875

American Queen Anne

In the 1920's used as residence for the plant manager of Penn Dixie Cement Corporation. Plant manager Conrad Miller was brother-in-law of former Georgia Tech head football coach Bobby Dodd.

Two-story garage/apartment building constructed in rear in 2007

1214 Main Street
 0P0030 072000
 HT-P-173

Contributing

Penn Dixie Worker House/Pensyl House
 1925

Craftsman

Sears, Roebuck & Co. kit house, assembled by local carpenter Willie Bell Roberts

FIVE ROOMS, BATH AND PORCH



Home-Kit
The Somers
 No. Crow's-Nest-Corner and Street
\$1,698.00

THE SOMERS is an attractive and inexpensive bungalow of five rooms with vestibule, bath, and built-in cupboard. It has a front porch across the entire house, so arranged that it is easily converted to a sun room by glazing the open parts. The porch measures 22 feet 6 inches by 8 feet.

The Living Room. The front door leads from the porch into the vestibule which has a closed opening into the living room. Size of living room, 12 feet 8 inches by 12 feet 2 inches. Furniture and chairs can be grouped to please because of the wall and floor space. Three front windows, two high each, on the side, provide an abundance of light and air.

The Dining Room and the living room are practically one large room, as they are connected by the wide casual opening. The dining room has a recessed bay with three windows. Size, 12 feet 4 inches by 14 feet.

The Kitchen. A swinging door from the dining room leads to the kitchen that is lit from two windows. Floor area of the kitchen is 8 feet by 11 feet 9 inches. There is space for the sink, the range, the table and chair. The built-in cupboard is located opposite the stove for easy work. Sink to the basement and through a door. Another door leads to porch and grade.

The Bedrooms. Directly off the dining room is an open hall that connects with the two bedrooms and bath. Each bedroom has a closet chest, and is lighted by window.

The Bathroom has a medicine case, and is lighted by a window. All of the plumbing can be roughed-in on one wall, saving installation expense.

The Basement. Room for furnace, laundry and storage.

Height of Ceiling. Main floor, 9 feet from floor to ceiling. Basement, 7 feet from floor to joists.

The house has been built at Akron, Pa., Park Side, Elvewood, Tom, Moore, Glen, Lawrence, The Ambassador, R. M., Maxwell, 26th, and other cities.

What Our Price Includes
 At the price named we will furnish all the material to build the basement basement, including:
 Lumber, Lath,
 Clear Red Cedar Shingles for Roof and Siding
 Plaster, Cement, One Quality Yellow Pine
 Joists, Sillings, One Side Girders
 Floor Joists, Clear Yellow Pine
 Finish Flooring, Clear Yellow Pine
 Porch Ceiling, Clear Yellow Pine
 Finishing Casement
 High Grade Millwork, one piece 42 and 3611
 Sash and Doors, White Pine with First Grade Panels
 of Pine
 Tiles, Beautiful Grays Yellow Pine
 Windows of California Clear White Pine
 Casement, Medicine Case
 Case Trunk and Case
 40 Lb. Building Paper, 400 lbs. Weight
 Standard Design Hardware (see page 113)
 Plans for Two Cows (Grade 750)
 Sinks for Kitchen or Bath for Two Wash Basins,
 Sinks and Vessels for Lavatory and Toilet
 Sanitation of "Honor 351" Houses on Pages
 12 and 13.

OPTIONS
 Steel Plates and Metal Posts to hold the floor of wood laid \$22.00 extra. See page 82.
 Outside of each window, prepared 2-pane, heated of wood \$24.00 per pair. \$40.00 extra.
 Outside of each window, prepared 2-pane, heated of wood, 2-pane and 2-pane, 100 lb. weight.
 Make floor in living, dining and bathroom, instead of yellow pine, \$10.00 extra.
 Sash and Doors and Windows, \$40.00 extra.
 Sash and Windows, \$20.00 extra.
 For prices of Plumbing, Heating, Wiring, Electric Fixtures and Details see page 115.

Can be built on a lot 30 feet wide.
 This house can be built with porch or without. (See page 2)



HERE is one of the many houses we have from Sears, Roebuck and Co.
 Customers interested will find that a choice of our new complete built from your material and show ready a new style design. It will be set out in the material and building job for your home-construction in these conditions, \$1.00.
 CHARLES MILLER,
 P. O. Box 8, West Block St., Philadelphia, Pa.

Page 68 99 SEARS, ROEBUCK AND CO.

Source: 1926 Modern Homes Catalog, page 68 Available from 1926 through 1929

1216 Main Street
0P0030 071000
HT-P-174

Contributing

Penn Dixie Worker House/Salon Seven

1925

Craftsman

Sears, Roebuck & Co. kit house, assembled by local carpenter Willie Bell Roberts

1218 Main Street
0P0030 070000
HT-P-175

Contributing

Penn Dixie Worker House/

1925

Craftsman

Sears, Roebuck & Co. kit house, assembled by local carpenter Willie Bell Roberts

Rear addition in 2004

1220 Main Street
0P0030 069000
HT-P-176

Contributing

Penn Dixie Worker House/

1925

Craftsman

Sears, Roebuck & Co. kit house, assembled by local carpenter Willie Bell Roberts

1222 Main Street
0P0030 068000
HT-P-177

Contributing

Penn Dixie Worker House/Lush Arts Studio

1925

Craftsman

Sears, Roebuck & Co. kit house, assembled by local carpenter Willie Bell Roberts

Front porch enclosed

923 Clinchfield Circle
0P0030 067000
HT-P-166

Contributing

Penn Dixie Worker House/Crowe House

1925

Craftsman

Sears, Roebuck & Co. kit house, assembled by local carpenter Willie Bell Roberts

921 Clinchfield Circle
0P0030 066000
HT-P-167

Contributing

Penn Dixie Worker House/Sanderson House

1925

Craftsman

Sears, Roebuck & Co. kit house, assembled by local carpenter Willie Bell Roberts

Wrought iron railing/columns replace original

1303 Forest Hill Road
OP0100 06A000
HT-P-164

Contributing

1874, relocated from Main Street to current location in 1962, only the center portion of the original house was moved
Carpenter Italianate
Detached garage in rear in 1982, Addition to rear of house in 2008



922 Clinchfield Circle
0P0100 005000
HT-P-169

Contributing

Penn Dixie Worker House/rental

1925

Craftsman

Sears, Roebuck & Co. kit house, assembled by local carpenter Willie Bell Roberts

Attached carport and side addition

924 Clinchfield Circle
0P0100 004000
HT-P-168

Contributing

Penn Dixie Worker House/Mimbs House

1925

Craftsman

Sears, Roebuck & Co. kit house, assembled by local carpenter Willie Bell Roberts

Front porch enclosed

1300 Main Street
0P0100 003000
HT-P-178

Contributing

Penn Dixie Worker House/Tomlinson House

1925

Craftsman

Sears, Roebuck & Co. kit house, assembled by local carpenter Willie Bell Roberts

Detached carport in 1984

1302 Main Street
0P0100 002000
HT-P-179

Contributing

Penn Dixie Worker House/rental

1925

Craftsman

Sears, Roebuck & Co. kit house, assembled by local carpenter Willie Bell Roberts

1304 Main Street
0P0100 001000
HT-P-180

Contributing

Penn Dixie Worker House/QSI Office

1925

Craftsman

Sears, Roebuck & Co. kit house, assembled by local carpenter Willie Bell Roberts



Design Guidelines

*Acworth Historic Districts
Acworth, Georgia*





Street Scene - Acworth, Ga. 1948

INTRODUCTION CONTENTS

Preface

[PG 5] Provides a summary of the purpose and intent of local design guidelines; reviews local preservation initiatives, including the ordinance and the establishment of a design review board.

Intent Statement

Historic Preservation Ordinance

Historic Preservation Commission (HPC)

Historic Properties

[PG 6-7] Reviews the documentation and recognition of Acworth's historic properties, including national, state, and local programs and status.

Historic Resource Survey

National Register of Historic Places

Acworth Historic Districts

Design Review Process

[PG 8-9] Outlines the design review process, providing a flow chart and answers to the most common questions.

Common Questions

Administration

Design Review Chart

Standards & Guidelines

[PG 10-11] Introduces the national guidelines and sets the stage for the following local guidelines: *Commercial* [PG 23-55] and *Residential* [PG 57-95]; includes a glossary of the most commonly used terms [PG 96-97].

Secretary of the Interior's Standards

General Guidelines

Visual Character

[PG 12-21] Gives the historical background of Acworth's pattern of development and describes the types of resources found in the town.

Historic Context

Building Types

Architectural Styles

January 2003

Produced for:
The City of Acworth
Historic Preservation Commission
Acworth, Georgia

Produced by:
Kenneth L. Kocher
Piedmont Preservation
Athens, Georgia

PREFACE

Intent and Purpose

This booklet was initiated by the Acworth Historic Preservation Commission and financed by the City of Acworth on behalf of its current and future citizens. The purpose of this booklet is to provide information on local preservation measures, the design review process, and the visual character which defines Acworth's downtown and residential areas. The remainder of the booklet outlines design guidelines for commercial and residential areas. The guidelines listed and illustrated herein are designed to assist decision makers --- property owners, developers, contractors, and commissioners --- in developing design solutions which satisfy Acworth's historic preservation ordinance.

Historic Preservation Ordinance

“In support and furtherance of its findings and determination that the unique historical, cultural, and aesthetic heritage of the City of Acworth is among its most valued and important assets,” the City of Acworth adopted a historic preservation ordinance June 19, 1986. The ordinance is designed to preserve the community's identity and historic character, promote harmonious growth in relationship to historic properties, to strengthen community pride and awareness of historic assets, to stabilize property values and encourage investment in historic areas, to capture the benefits of tourism and economic development, and to maintain and protect historic properties. By preserving its unique historic character, the City ensures that future generations will enjoy the benefits of Acworth's rich architectural heritage.

Historic Preservation Commission

The Historic Preservation Ordinance establishes the Historic Preservation Commission (HPC), the volunteer board which serves as part of the planning functions of the City of Acworth. The HPC is charged with the responsibility of initiating local designation, the design review process, public education and awareness, securing preservation related grant funding, and preservation planning and research. The Commission consists of seven appointed members, who serve three-year terms without monetary compensation.



HISTORIC PROPERTIES

Historic Resource Survey

Recognizing the value of its historic resources the City of Acworth initiated a Historic Resource Survey in 1997 to identify and research historic properties within the city limits. The resulting survey report indicated that a portion of the town was eligible to be listed as a district in the National Register of Historic Places.

National Register of Historic Places

Acworth currently has three listings in the National Register of Historic Places - one district and two individual properties. The Collins Avenue Historic District was listed in 2001 and includes several properties bordering a section of the street from which it gets its name. The historic significance of Bethel AME Church and the Stephen D. Cowen House were recognized in 2002 when they each were listed in the National Register as individual properties. Currently work is proceeding on registering the core historic commercial and residential areas of Acworth. This district will be known as the Railroad Corridor Historic District.

Acworth Historic Districts

Listing in the National Register bestows considerable honor but provides little protection for historic properties. The Mayor and Council of Acworth therefore, in order to protect their historic character, locally designated the Collins Avenue Historic District, Bethel AME Church, and the Stephen D. Cowen House. This local designation charges the Acworth Historic Preservation Commission with protection of the historic character of these properties as outlined in the Acworth Historic Preservation Ordinance. The proposed Railroad Corridor Historic District is soon to be considered for designation as well.

The Common Questions

What is design review?

The Historic Preservation Ordinance provides for a design review process. Design review consists of the evaluation of any proposed exterior work upon a property within a designated district. Both minor and extensive projects must be reviewed and approved prior to beginning work. The design review process is often triggered by a building permit application; however, building permits can not be issued until design review is complete. Although some types of work projects, such as installation of a walkway or a satellite dish, may not require a building permit, design review is still required.

Which properties require design review?

All designated properties require design review. Designated properties include all properties within historic districts and any individually designated sites. Please note that design review covers both historic and non-historic properties in a historic district. The city's Official Zoning Map shows all designated districts and properties. A call to the Historic Preservation Planner can confirm whether or not a property is designated.

What type of work requires design review?

All work involving a change to an exterior feature of a designated property requires design review. Projects that physically alter the property include but are not limited to: changes in site or setting, repair or rehabilitation, relocation or demolition, and new construction or additions.

Neither interior alterations nor a change in the use of the property require design review. The Historic Preservation Ordinance applies only to the external aspects of the property and regulates neither zoning nor land use. The HPC does not review planting or repainting. Ordinary maintenance does not require design review.

What is a Certificate of Appropriateness?

When planning a work project, an owner must submit a completed application for a Certificate of Appropriateness (COA). Applications are available from and should be submitted to the Historic Preservation Planner. The deadline for applications is the first day of the month in which the application will be reviewed. Please contact the Historic Preservation Planner for regular meeting dates and times. Utilizing design guidelines and the general standards for the rehabilitation of historic properties, the HPC must decide to approve or deny the application. If the application is approved, a Certificate of Appropriateness is issued and design review is complete.

What should an application include?

In order that the Commission may make an informed decision, completed applications must be accompanied by support materials. Illustrations may include site plans, elevations, and floor plans drawn to a standard architectural scale, e.g. 1/4 inch equals one foot. Photographs of the building, site, and neighboring properties are also helpful. Support materials may differ according to the type and size of the project. The application and support materials must be submitted at the same time.

What could happen if work begins before design review?

If work is initiated prior to approval of a COA application or to obtaining a building permit, a stop work order may be issued. If these requirements are not met, the property owner may face fines or an order to restore the original condition of the property.

Where can additional assistance be found?

This booklet outlines design guidelines which are useful for project planning; however, the HPC does not actually develop plans or designs. Property owners are encouraged to review the design guidelines set forth in the booklet prior to planning any rehabilitation work or new construction. Familiarity with the design guidelines will facilitate design review. For information concerning the process or for assistance with the preparation of the application, contact the Historic Preservation Planner at (678) 801-4037.

Are there any other review procedures?

Review of projects by the HPC may not be the only review required before work may proceed. Other city departments and commissions may be required to examine a project for compliance with existing zoning regulations, building codes, and sign or landscape ordinances.

DESIGN REVIEW PROCESS

Administration

Property owners within the Acworth Historic District enjoy the advantages of increased economic value and a built environment protected from unsympathetic changes. The Historic Preservation Commission (HPC) protects the rights and investments of property owners and business establishments through the design review process. By preserving and maintaining visual character, the HPC ensures that citizens and visitors alike will enjoy the benefits of Acworth's historic built environment.

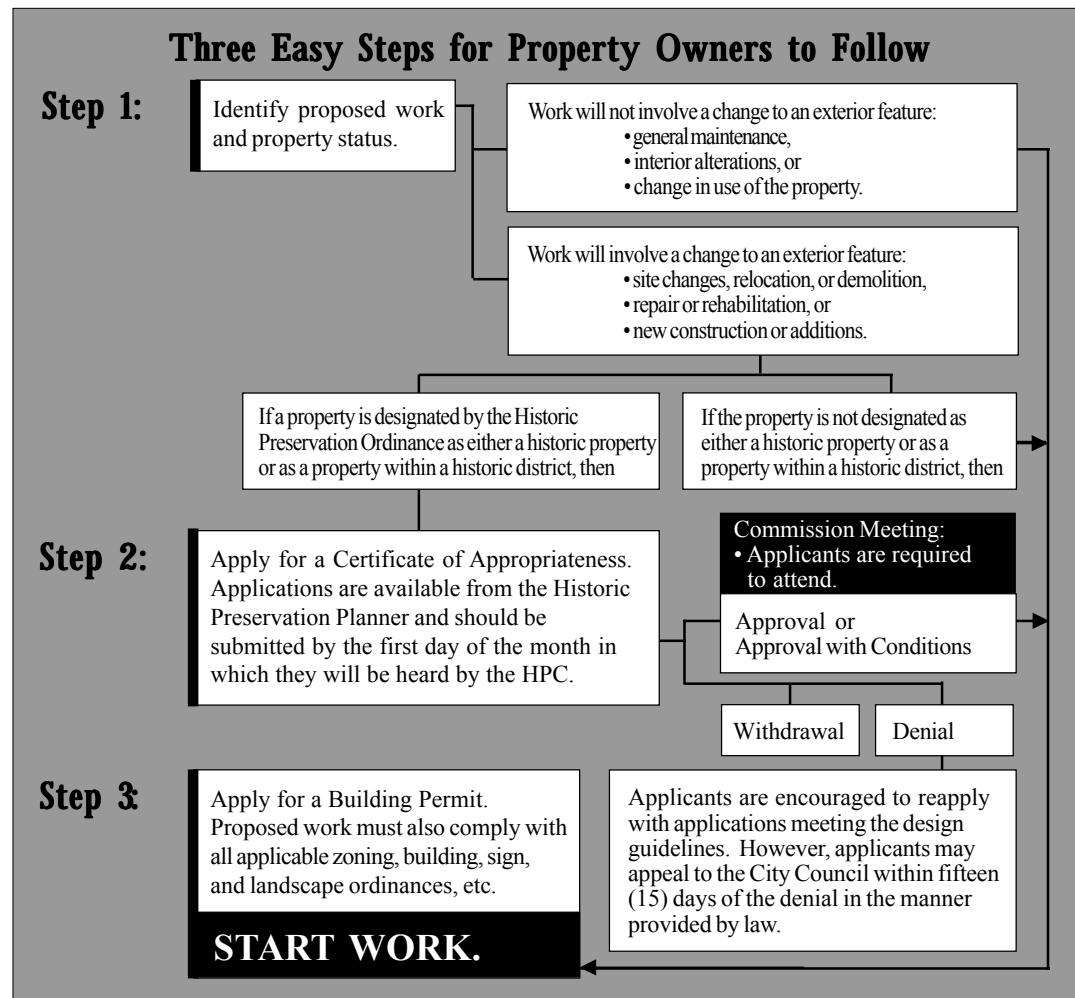

Secretary of the Interior's Standards for Rehabilitation

Rehabilitation is defined as the act or process of making possible a compatible use for a property through repair, alterations, and additions while preserving those portions of features which convey its historical, cultural, or architectural values.

The following Standards are to be applied to specific rehabilitation projects in a reasonable manner, taking into consideration economic and technical feasibility.

- ▶ A property shall be used for its historic purpose or be given a new use that requires minimal change to its distinctive materials, features, spaces, and spatial relationships.
- ▶ The historic character of a property shall be retained and preserved. The removal of distinctive materials or alteration of features, spaces, and spatial relationships that characterize a property shall be avoided.
- ▶ Each property shall be recognized as a physical record of its time, place, and use. Changes that create a false sense of historical development, such as adding conjectural features or elements from other historic properties, shall not be undertaken.
- ▶ Changes to a property that have acquired historic significance in their own right shall be retained and preserved.
- ▶ Distinctive materials, features, finishes, and construction techniques or examples of craftsmanship that characterize a property shall be preserved.
- ▶ Deteriorated historic features shall be repaired rather than replaced. Where the severity of deterioration requires replacement of a distinctive feature, the new feature shall match the old in design, color, texture, and where possible, materials. Replacement of missing features shall be substantiated by documentary and physical evidence.
- ▶ Chemical or physical treatments, if appropriate, shall be undertaken using the gentlest means possible. Treatments that cause damage to historic materials shall not be used.
- ▶ Archeological resources shall be protected and preserved in place. If such resources must be disturbed, mitigation measures shall be undertaken.
- ▶ New additions, exterior alterations, or related new construction shall not destroy historic materials, features, and spatial relationships that characterize the property. The new work shall be differentiated from the old and shall be compatible with the historic materials, features, size, scale and proportion, and massing to protect the integrity of the property and its environment.
- ▶ New additions and adjacent or related new construction shall be undertaken in such a manner that , if removed in the future, the essential form and integrity of the historic property and its environment would be unimpaired.

**STANDARDS
& GUIDELINES**

design guidelines

Developed at the request of the Acworth Historic Preservation Commission, the design guidelines within this booklet are based specifically upon the visual character of Acworth's historic districts and are divided into two sections: Commercial and Residential. The Commission also adheres to the *Secretary of the Interior's Standards for Rehabilitation*, which present general guidelines for the rehabilitation of historic buildings used by commissions throughout the nation.

rehabilitation

Rehabilitation is a sensitive approach to historic design and materials during simple repairs and during alterations. Rehabilitation permits contemporary use while preserving those features of the building which are significant to its historic character. Such character-defining features are an integral part of each building and contribute to the visual character of the surrounding area.

new construction

New construction can be compatible with historic properties and buildings through attention to design and materials. In addition, existing non-historic buildings can increase their compatibility by following similar design considerations during renovation projects. Sensitive design of new construction is imperative when planning either new buildings, additions to existing buildings, or renovating intrusive non-historic buildings.

special consideration

Institutional properties, both public and private, are often the exception to the rule. While historic institutional properties should follow the same guides for rehabilitation, new institutional buildings may vary from the surrounding district in some respects to distinguish the property's civic importance. For example, a new government building may utilize a deeper setback than surrounding historic buildings while using a similar exterior material.

demolition

The demolition of historic buildings diminishes the built environment and creates unnecessary waste. Demolition of a historic structure is only approved in very rare, specific, and narrowly defined circumstances, and no demolition occurs without approval of post-demolition plans. The aspects the commission consideration include but are not limited to: age, integrity, significance, condition, alternatives, and overall effect.

relocation

Relocation falls into one of three categories: 1) removing a structure from a historic district, 2) moving a structure into a historic district, or 3) moving a structure to a different location within a historic district. Different criteria are applied to each. Proposed relocation out of a historic district constitutes a loss and therefore, demolition guidelines apply. New construction guidelines apply for proposed relocations into a historic district. For proposed relocations within a historic district, the following considerations apply: age, previous relocation, compatibility of the new site, significance, condition, alternatives, and overall effect.

Beginnings

Fueled by the discovery of gold in North Georgia and the desire to open land for white settlement, by the 1820s the state legislature grew anxious to gain control of unceded Indian territories. In 1831 the state legislature preemptively directed the governor to survey and distribute all lands west of the Chattahoochee River and north of Carroll County creating a single enormous county called Cherokee County.

By late 1832 the survey of North Georgia was complete. Around the same time the state legislature broke Cherokee County in ten smaller, more manageable counties, and thus Cobb County was born.

Railroad

In 1836 the state legislature authored and provided funding for a railroad to extend north from Atlanta (then Marthasville) to the Tennessee state line (to later connect to Chattanooga and the Tennessee River). The Western and Atlantic railroad, as it was known, was to be owned by the State of Georgia. By 1843 the railroad extended some 30 odd miles north of Atlanta where it crossed Land Lot 30 in northwestern Cobb County. The owner of Land Lot 30, Alexander Northcutt, was fortunate that this location was where the Western and Atlantic decided to build a watering station for the railroad. Quite naturally, a small community of residences and commercial enterprises known as Northcutt Station developed around the stop to capitalize on the flow of settlers, travelers, and merchandise. Thus, the foundation of Acworth was laid.

Appropriate to the town's relationship to the railroad, the name "Acworth" was given to the town by a transplanted New Englander by the name of Joseph Gregg. Gregg was a civil engineer employed by the builder of the railroad, Colonel Stephen H. Long. It is believed that Gregg's association with the building of the railroad led to his eventual residence in Acworth.

The development pattern established by the railroad is clearly present today. Though transportation patterns have shifted modern development, Acworth's historic downtown, straddling the railroad corridor, remains the community's business center.



VISUAL CHARACTER HISTORIC CONTEXT

War

With secession impending and the specter of war looming, Acworth incorporated on December 1, 1860. The corporate limits extended one-half mile in radius from the Western and Atlantic Depot. Ironically, the prosperity the railroad brought in prior years would now bring destruction as a key strategic asset in the North Georgia theater in the War Between the States.



As Union soldiers moved into north Georgia in the spring of 1864, the goals of Generals Sherman and Grant were simple: shatter the transportation structure (the Western and Atlantic) connecting Georgia to the battlefields of northern Virginia and lay waste to the industrial and agricultural underpinning of the state.

In June of 1864 Sherman's army occupied Acworth and the Western and Atlantic to the north. Sherman found Acworth abandoned as most civilians had fled to surrounding counties beyond the scope of fighting. Sherman soon moved on from Acworth, but the community remained a staging area for the impending battle with Confederate forces at Kennesaw Mountain. Later, Union troops without order and acting on their own volition, set fire to the town of Acworth. With a few exceptions the small community was laid to waste.

Industrial Development and Economic Prosperity

Following the War, the city of Acworth and the Western and Atlantic set to rebuilding. The city was reincorporated in 1870 including the area within a one mile radius of the Western and Atlantic depot. The years following Reconstruction brought unprecedented prosperity to the small community as the railroad and industry made Acworth an exemplary New South community. Acworth offered railside sites and tax exemptions to industries willing to establish facilities there.

Through the turn of the century Acworth continued to serve primarily as a center to the surrounding agricultural community. The community relied upon industry and shipping to process and move agriculture products on to other markets. As was true with most of the South, Acworth was highly dependent on the staple of cotton. By the early 1880s, it was estimated that





upward of 6,000 bales of cotton were shipped from Acworth yearly. Though the community remained dependent upon cotton, some industrial diversification occurred and by the turn of the century the town possessed two flour mills and a tannery. It was during this period that most of the historic commercial core of Acworth developed as well as a healthy portion of the community's residential historic core.

The reliance upon cotton continued well into the early twentieth century when the Boll Weevil wrought economic collapse on the region. Recognizing the need for further diversification of industry, Acworth was able to attract new industry to offset the shifting economic base. Examples include the arrival of textile manufacturing operations such as the Elizabeth Bartlett Mill and the Unique

Knitting Company. This trend continued into the 1940s when Royce Manufacturing Company moved to Acworth to open a facility for the production of stuffed toys and (later) life vests and boat cushions.

Tourism and Suburbia

By the 1910s, a new industry was on the rise in America – automobile tourism. In response to the desire to exploit this new industry (in addition for the desire to provide an interstate highway system to aid farmers and promote the common defense) the Dixie Highway was constructed, not by the federal government, but rather through a common effort on the part of state and local officials along the proposed route. With the Dixie Highway came northern tourists to visit sites such as the recently authorized Kennesaw National Battlefield site (1917) and spend money in the South. Renamed U.S. Route 41 in 1926 when it was adopted as a component of the fledgling federal highway system, the Dixie Highway passed through the heart of Acworth.

In the second half of the twentieth century two events secured the future of Acworth as a bedroom community of Atlanta. First, in the 1950s the Army Corps of Engineers completed the impoundment of Lake Acworth thereby increasing the community's attractiveness as a commuter and recreational destination. Later in 1977, Interstate-75 was opened north of Atlanta providing an easy commute to and from the town.

Today Acworth continues to serve as a bedroom community of metropolitan Atlanta. Aware of the preservation issues brought forth by the rapid expansion of its larger neighbor, the Historic Preservation Commission has recommended the designation of both National Register and Local Historic districts as a first step toward preserving the community's historic core.



VISUAL CHARACTER BUILDING TYPES

Structures make the most obvious contribution to visual character and are commonly discussed in terms of **building type**. In general, a building type refers to structures which share a similar arrangement of features. A one story example is called a cottage whereas the same form with two stories is called a house. A building type can indicate whether a building is rare or common in an area and, in some cases, identify the historical period in which the structure was most likely built.



Single Pen, 1850-1900

- ▶ roof: side gable
- ▶ rooms: one
- ▶ facade doors: one
- ▶ chimneys: gable end

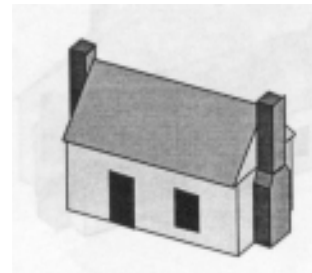
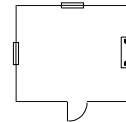

Hall-Parlor, 1870-1930

- ▶ roof: side gable
- ▶ rooms: two
- ▶ facade doors: one
- ▶ chimneys: gable end

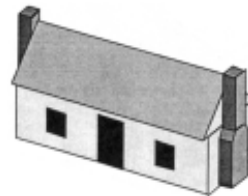
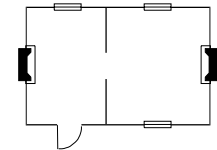

Central Hall Cottage, 1830-1890

- ▶ roof: side gable
- ▶ rooms: two with central hall
- ▶ facade doors: one, centered
- ▶ chimneys: both gable ends

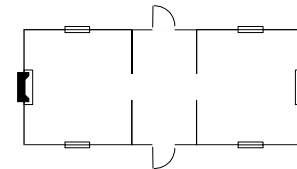

Saddlebag, 1830-1930

- ▶ roof: side gable
- ▶ rooms: two
- ▶ facade doors: one or two
- ▶ chimneys: center ridge

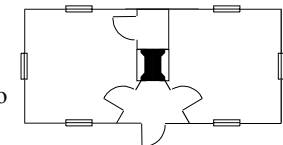

Shotgun, 1870-1930

- ▶ roof: front gable or hip
- ▶ rooms: two or more in line
- ▶ doors: one
- ▶ chimneys: ridge

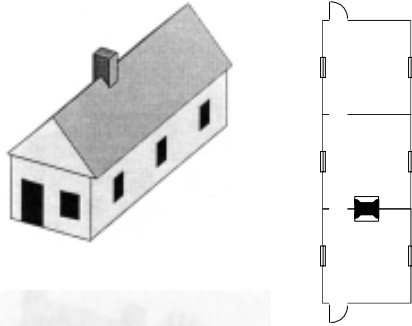
***Pyramidal Cottage, 1910-1930***

- ▶ roof: pyramidal
- ▶ rooms: four equal
- ▶ facade doors: one
- ▶ chimneys: lateral exterior

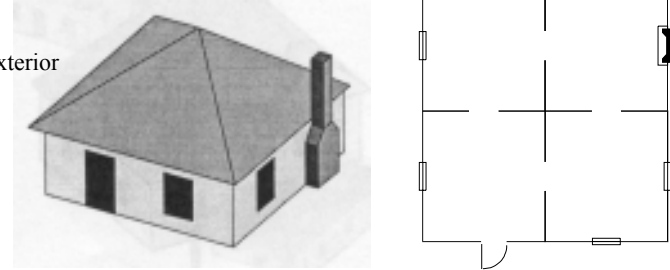
***Gabled Ell Cottage, 1875-1915***

- ▶ roof: cross gable
- ▶ rooms: three or more;
(in a T or L often with a hallway)
- ▶ doors: one
- ▶ chimneys: on ridges or gable end

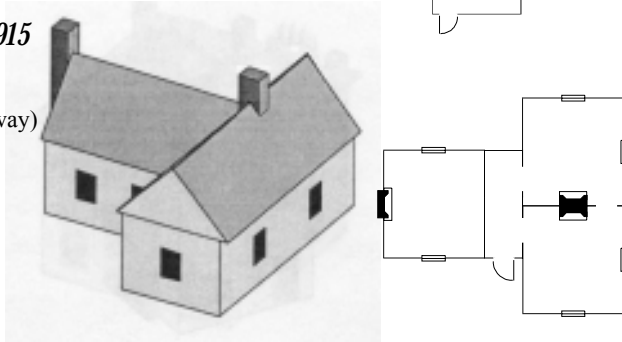
***Georgian Cottage, 1850-1930***

- ▶ roof: hip or side gable
- ▶ rooms: four;
stacked with center hallway
- ▶ doors: one, centered
- ▶ chimneys: two,
symmetric, on roof slope

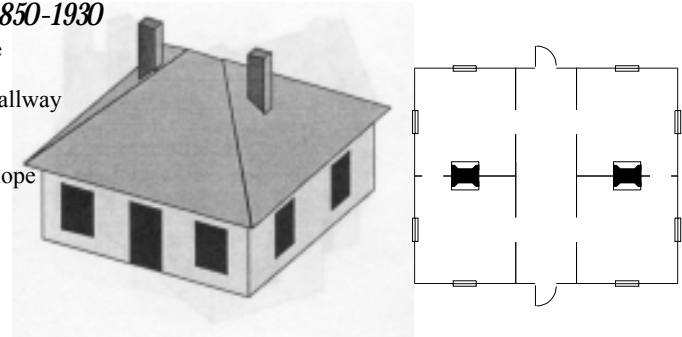
***New South Cottage, 1890-1925***

- ▶ roof: hip with gables
- ▶ rooms: five or more with a hallway
- ▶ doors: one, central
- ▶ chimneys: on roof slopes

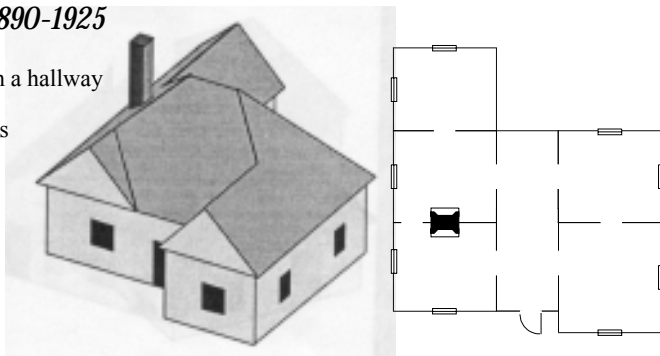
***Queen Anne House/Cottage, 1880-1900***

- ▶ roof: hip with gables
- ▶ rooms: four or more
with no hallway
- ▶ doors: one, central
- ▶ chimneys: on roof slope

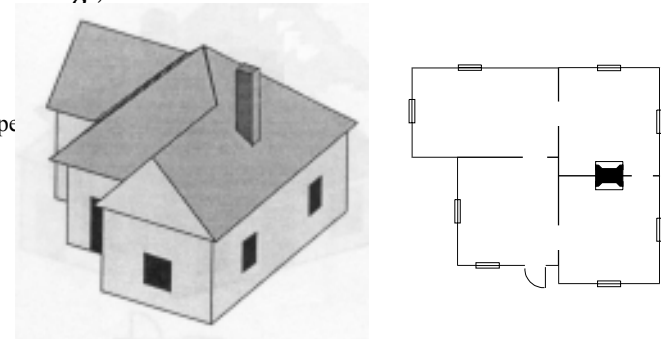

VISUAL CHARACTER BUILDING TYPES

I-House, 1840-1890

- ▶ roof: side gable
- ▶ rooms: two with central hall
- ▶ facade doors: one, centered
- ▶ chimneys: gable ends

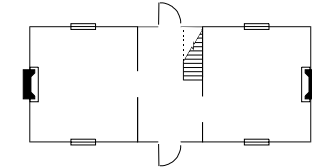
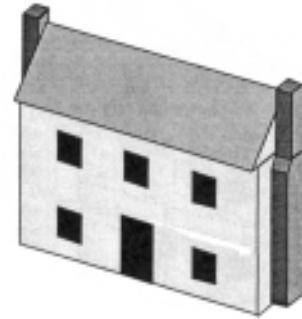

Gabled Ell House, 1870-1920

- ▶ roof: cross gable
- ▶ rooms: three or more;
(in a T or L often with a hallway)
- ▶ doors: one
- ▶ chimneys: on ridges or
gable end

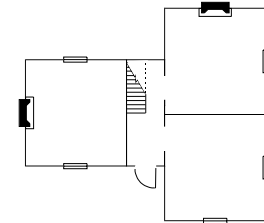
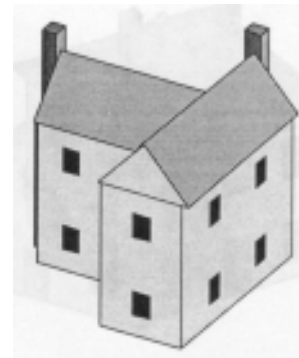

Queen Anne House, 1880-1900

- ▶ roof: hip with gables
- ▶ rooms: four or more
with no hallway
- ▶ doors: one, central
- ▶ chimneys: on roof slopes

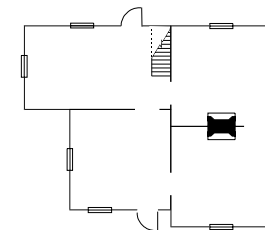

Georgian House, 1850-1930

- ▶ roof: hip or side gable
- ▶ rooms: four; stacked with center hallway
- ▶ doors: one, centered
- ▶ chimneys: two, symmetric, on roof slope *or* two on each side

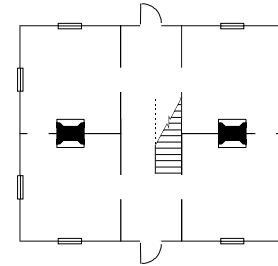
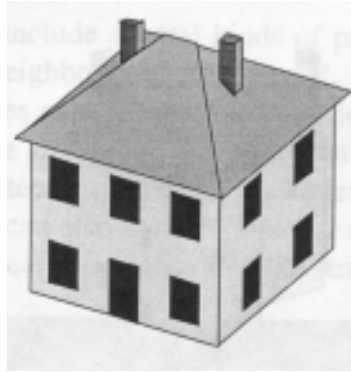

American Foursquare, 1915-1930

- ▶ roof: pyramidal
- ▶ rooms: four on each floor
- ▶ doors: one, off-center
- ▶ chimneys: varied

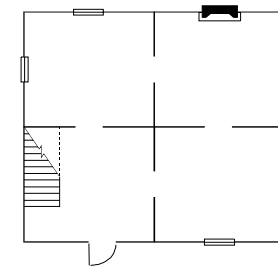
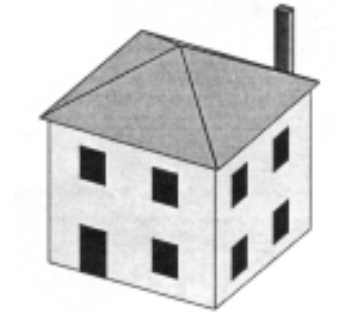

Bungalow, 1900-1950

- ▶ roof: front gable, hip, side gable, or cross gable
- ▶ rooms: five or more with varied, irregular floor plans
- ▶ doors: varied
- ▶ chimneys: varied

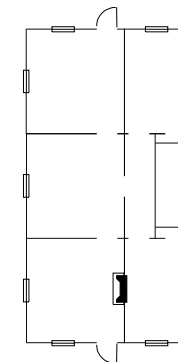
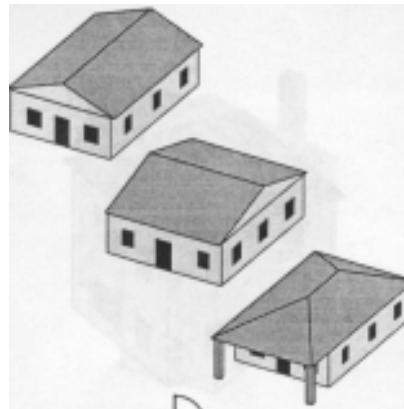

VISUAL CHARACTER
ARCHITECTURAL STYLES

Style, the external decoration of a building, is another classification method for describing structures. When all the defining aspects of a particular style are present, a building may be labeled as **high style**. If only a few stylistic details are present, the building is referred to as influenced by a style or as having **elements of a style**. High style buildings are few in number and are often designed by an architect; whereas, buildings with elements of a style are quite common as local interpretations of an architectural style.



Greek Revival - 1825-1860

- ▶ roof: hipped with a low pitch
- ▶ detail/materials: clapboard, classical columns, heavy entablature
- ▶ door: symmetrically oriented, framed by sidelights and transom
- ▶ windows: double-sashed, 9/9
- ▶ porch: full-height, full-facade

Gothic Revival - 1840-1880

- ▶ roof: side gabled with a steep pitch often with center or paired gables
- ▶ detail/materials: clapboard or board-and-batten; elaborate porch supports; vergeboards; finials; window molding
- ▶ door: sidelights and transom occur
- ▶ windows: double-sashed, 2/2
- ▶ porch: one store, full-facade



Italianate, 1840-1885

- ▶ roof: hipped
- ▶ detail/materials: clapboard, paneled boxed columns, detailed cornices with brackets, heavy window crowns
- ▶ door: paneled surrounded by transom and sidelights
- ▶ windows: double-sashed, 6/6
- ▶ porch: one-story, full-width



Queen Anne - 1880-1910

- ▶ roof: multiple gables
- ▶ detail/materials: clapboard, turned posts, sawnwork
- ▶ door: asymmetrically oriented
- ▶ windows: double-sashed
- ▶ porch: one story wrap, balcony

Folk Victorian - 1870-1910

- ▶ roof: usually gabled
- ▶ detail/materials: clapboard, Italianate, Queen Anne, and Gothic inspired ornament primarily applied to porches and cornices
- ▶ door: symmetrically oriented
- ▶ windows: double-sashed
- ▶ porch: asymmetric, one story, often wrapping

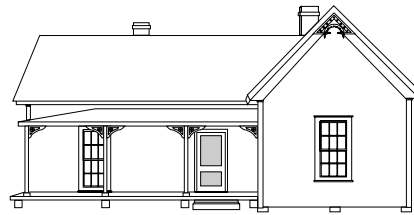

NeoClassical, 1895-1950

- ▶ roof: hipped with a low pitch
- ▶ detail/materials: clapboard, classical columns, heavy entablature
- ▶ door: symmetrically oriented, framed by sidelights and transom
- ▶ windows: double-sashed
- ▶ porch: full-height, full-facade

Colonial Revival, 1880-1955

- ▶ roof: side gable with a steep pitch, dormers
- ▶ detail/materials: brick, classical columns
- ▶ door: symmetrically oriented, classical door surround
- ▶ windows: double-sashed, 9/9
- ▶ porch: portico



VISUAL CHARACTER
ARCHITECTURAL STYLES

Tudor, 1890-1940

- ▶ roof: cross gables, steeply pitch
- ▶ detail/materials: brick, crenulations, stonework, elaborate chimney
- ▶ door: asymmetrically oriented, Tudor arch
- ▶ windows: double-sashed, casement, arched
- ▶ porch: entry porch, integrated



Craftsman, 1905-1930

- ▶ roof: gabled with a low pitch
- ▶ detail/materials: novelty board, knee braces, half-timbering
- ▶ door: framed by sidelights
- ▶ windows: double-sashed, 12/1
- ▶ porch: square columns on piers, porte-cochere

Minimal Traditional, 1930-1950

- ▶ roof: cross gables, steeply pitch
- ▶ detail/materials: brick, crenulations, stonework, elaborate chimney
- ▶ door: asymmetrically oriented, Tudor arch
- ▶ windows: double-sashed, casement, arched
- ▶ porch: entry porch, integrated





COMMERCIAL CONTENTS

Topics/Issues

Rehabilitation

[PG 24-39] Reviews the elements of historic construction that contribute to architectural style and building form for non-residential properties and areas. Highlights common mistakes to avoid and provides examples of changes subject to the design review process.

Roofs - Shape & Features

Materials

Details

Storefronts

Windows

Doors

Awnings

Additions

New Construction

[PG 40-49] Discusses the most significant aspects of new construction and its relationship to and potential impact upon the existing built environment for non-residential properties and areas. Highlights common mistakes to avoid.

Placement

Scale

Form

Openings

Materials & Details

Site & Setting

[PG 50-55] Outlines the accessory features commonly located on historic properties and reviews their relationship to the historic building for non-residential properties and areas. Highlights common mistakes to avoid and provides examples of changes subject to the design review process.

Walls & Fences

Signs

Modern Features

24 REHABILITATION ROOFS SHAPE & FEATURES

GOAL:

The primary goal is to maintain the original form of the building, especially as seen from the public view.

Actions to achieve the goal:

- ▶ Maintain the existing pitch and shape of the roof as seen from the public view. Changes hidden by existing parapets may be allowed.
- ▶ Replace existing roofing materials with the same type of roofing material. Changes hidden by existing parapets may be allowed.
- ▶ Secondary features and character defining materials which contribute to design should be retained.
- ▶ Maintain historic chimneys.
- ▶ Preserve historic skylights whenever possible.



Roof shape refers to the overall roof type and pitch. Roof features are any items attached to the roof, including parapets.

Glossary terms:

Character defining. An element whose design and material is associated with the age and style of a building and helps define its architectural style (e.g. tile roofing on Mission Style buildings).

Facade.

The front elevation or “face” of a building.

Pitch.

A term which refers to the steepness of roof slope.

Parapet.

A low protective wall located at the edge of a roof.

Public view.

That which can be seen from any public right-of-way.

Routine maintenance.

Any action performed in order to preserve a historic property including minor replacement of material with like material providing no change is made to the appearance of the structure or grounds.

- more terms found in the Glossary, p. 96

Changes requiring a COA

Examples:

- * Changing the pitch or shape of a roof.
- * Reroofing a roof with a material which is different than the existing material.
- * Removing or adding chimneys.
- * Stuccoing brick chimneys.
- * Repointing parapets or chimneys.

Changes not requiring a COA

Examples:

- * Reroofing a roof with the same material.
- * Repairing flashing.
- * Repairing existing gutters.

Common Mistakes

- ▶ *Replacing a flat roof with a gable roof which is not hidden by the parapet.* [A]
- ▶ *Removing ornamental roof features.* [B]
- ▶ *Repointing parapets with cement or not matching the original mortar joints.*
- ▶ *Adding a story to the building.* [C]

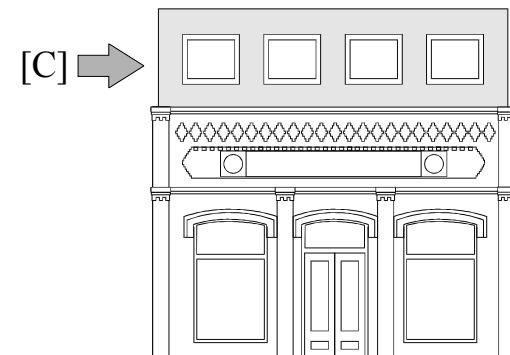
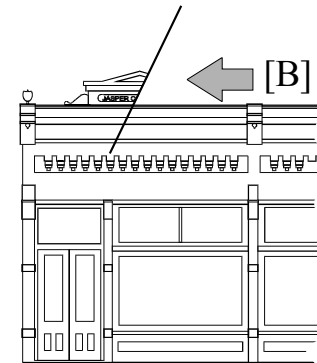
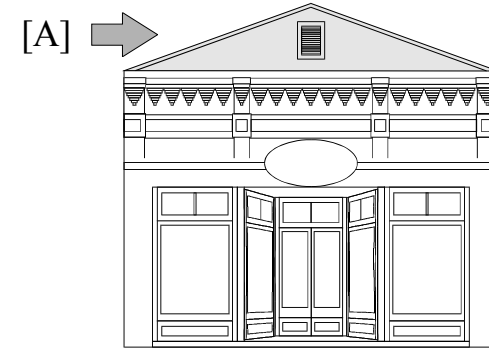

GOAL:

The primary goal is to maintain the texture created by historic exterior materials.

Actions to achieve the goal:

- ▶ Maintain historic exterior materials.
- ▶ Leave unpainted historic masonry unpainted and uncoated.
- ▶ Repair damaged exterior materials in-kind and only in the area of damage, rather than total replacement.
- ▶ Use a historic mortar mix [formula found in the glossary] and match the original mortar joints when repointing brick. Use a qualified professional mason.
- ▶ Use the gentlest means possible to clean exterior materials.



Materials, in this instance, refers to the materials of the exterior walls.

Glossary terms:

Bond.

A term used to describe the various patterns in which brick is laid.

Gentlest means possible.

The least abrasive, intrusive, damaging means of preserving historic material.

Historic mortar mix.

There are designated five mortar types. Typically, the repointing mortar for historic buildings will be a Type O or K mortar. Mortar specifications permit a range of proportions, but typical proportions by volume are: Type O - 1 part portland cement, 2 parts hydrated lime, and 9 parts sand; Type K - 1 part portland cement, 4 parts hydrated lime and 15 parts sand.

In-kind.

Using the exact same material when replacing a damaged element (e.g. using a wood element to replace a wood element).

Reveal.

The vertical profile created by the lap of siding, window casings, muntins, door surrounds, etc.

Siding. The exterior wall covering or sheathing of a structure.

- more terms found in the Glossary, p. 96

Changes requiring a COA

Examples:

- * Removing siding material (historic or non-historic).
- * Residing a building.
- * Painting unpainted masonry.
- * Entirely removing paint from a building.

Changes not requiring a COA

Examples:

- * Repainting a building.
- * Preparing surfaces for repainting.

Common Mistakes

- ▶ *Placing vinyl siding, aluminum, exterior insulating finishing systems (E.I.F.S. or synthetic stucco), or another type of synthetic siding on a historic building. [A]*
- ▶ *Sandblasting exterior surfaces which will remove historic brick's protective exterior. [B]*
- ▶ *Painting or "waterproof" coating unpainted masonry. "Waterproofing" rarely corrects water infiltration and often worsens damage by trapping the moisture.*

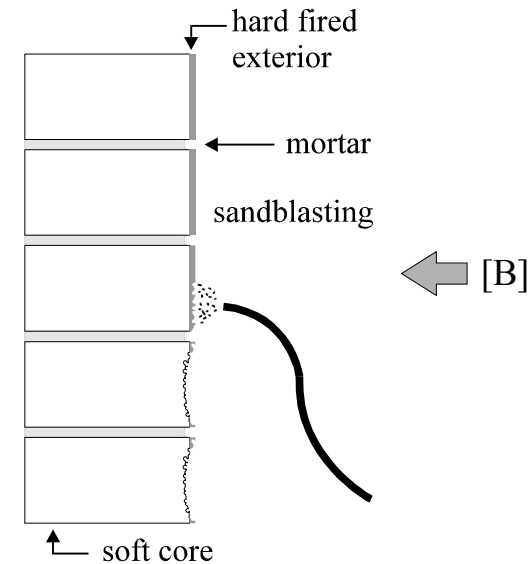
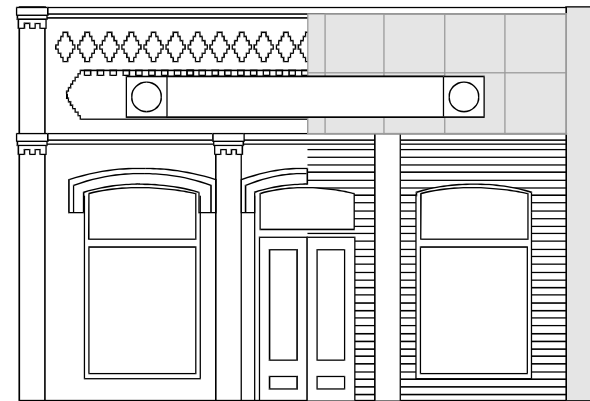

GOAL:

The primary goal is to maintain detail elements typical to commercial buildings, many of which impart a specific architectural style.

Actions to achieve the goal:

- ▶ Maintain and preserve historic details.
- ▶ Replace damaged details with details of matching material and matching design.
- ▶ Restore missing details when documentation of those elements are available.

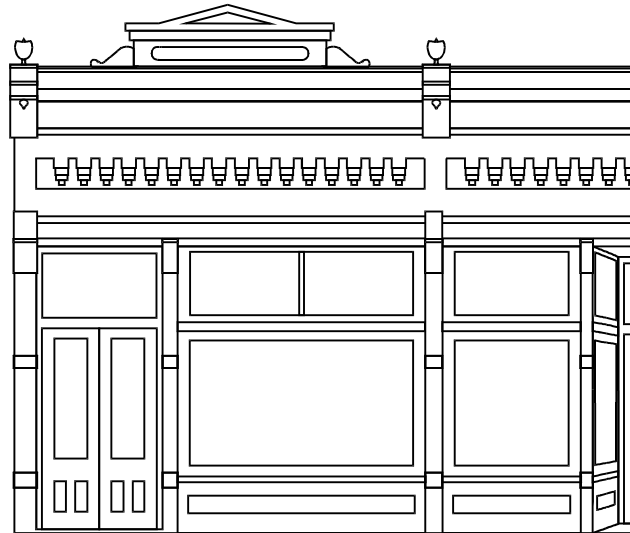

Details refers to those components on the exterior of the building which serve to embellish the structure. Details are often related to a specific architectural style.

Glossary terms:

Bracket.

A decorative support feature located under eaves or overhangs.

Capital.

Topmost member of a column or pilaster.

Cornice.

The uppermost, projecting part of an entablature, or feature resembling it.

Dentil.

One of a series of small, square, tooth or block-like projections forming a molding.

Documentation.

Evidence of missing elements or configurations of buildings such as architectural plans, historic photographs, or “ghosts” of missing elements.

Pilaster.

A pier attached to a wall, often with capital and base.

- more terms found in the Glossary, p. 96

Changes requiring a COA

Examples:

- * Removing architectural details.
- * Adding architectural details.

Changes not requiring a COA

Examples:

- * Repairing architectural details.
- * Repainting architectural details.

Common Mistakes

- ▶ *Adding architectural details where none existed before. [A]*
- ▶ *Removing details from a building. [B]*
- ▶ *Adding shutters which do not fit the windows. [A]*
- ▶ *Using stock, out of scale, details rather than matching the original details.*

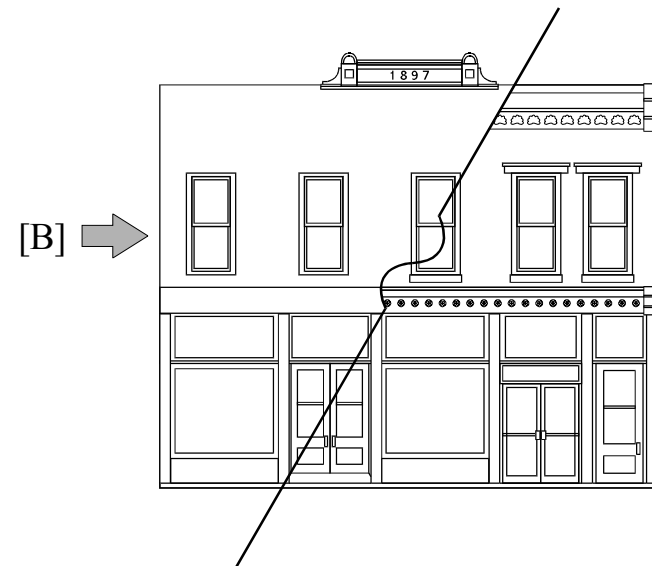
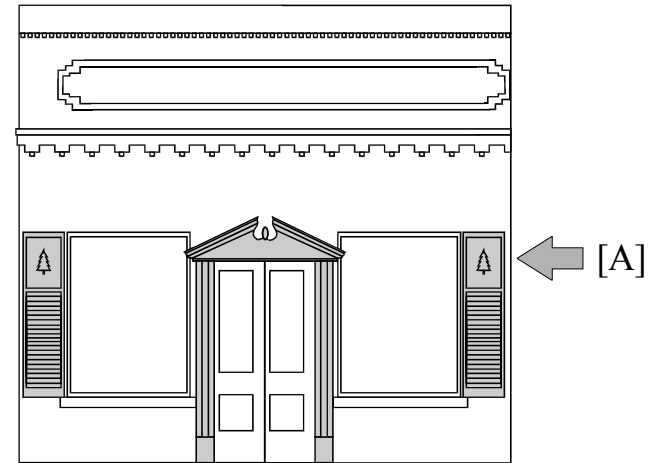

GOAL:

The primary goal is to maintain the original materials and configuration of the storefront.

Actions to achieve the goal:

- ▶ Maintain historic cast iron columns.
- ▶ Maintain transoms. Reopening previously covered transoms is encouraged.
- ▶ Maintain original window components replacing only damaged portions.
- ▶ Maintain the high ratio of window to wall in display area. Restoring previously enclosed display windows based on documentation or traditional design is encouraged.
- ▶ Maintain original bulkheads and if entire replacement is necessary, use materials similar to the original.

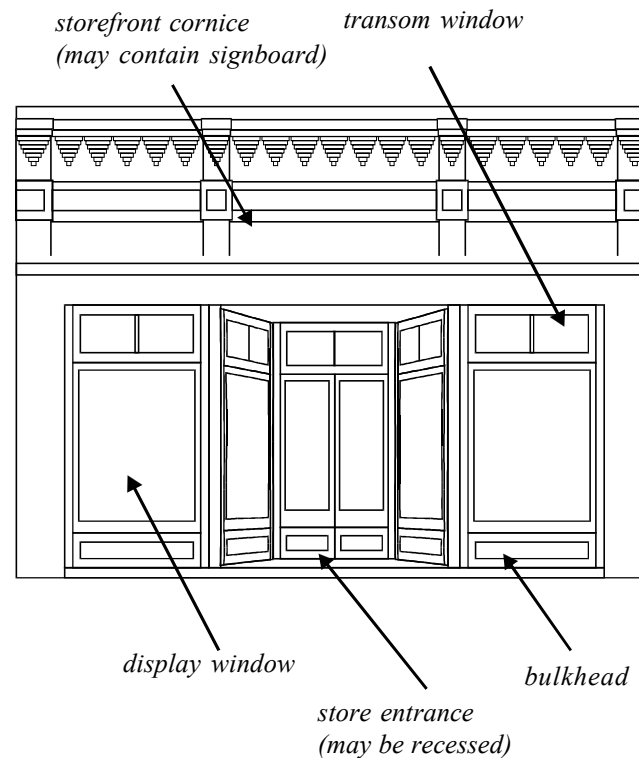

Storefront refers to the first floor of historic commercial buildings usually consisting of an entrance, display windows, transoms, and bulkheads.

Glossary terms:

Bulkhead.

The panel between framing members and beneath the display windows in a storefront; also known as a kickpanel or kickplate.

Cornice.

The uppermost, projecting part of an entablature, or feature resembling it.

Documentation.

Evidence of missing elements or configurations of buildings such as architectural plans, historic photographs, or “ghosts” of missing elements.

In-kind.

Using the exact same material when replacing a damaged element (e.g. using a wood element to replace a wood element).

Transom.

A small operable or fixed window located above a window or door.

- more terms found in the Glossary, p. 96

Changes requiring a COA

Examples:

- * Replacement of the existing storefront.
- * Replacement of a nonhistoric storefront.
- * Replacement of the bulkheads.
- * Replacement of all glass.

Changes not requiring a COA

Examples:

- * Repair of broken glass with clear glass.

Common Mistakes

- ▶ *Replacing wooden bulkheads with brick.* [A]
- ▶ *Replacing display windows with smaller or more elaborate windows.* [B]
- ▶ *Replacing display windows with wall surface.*
- ▶ *Placing window air conditioners in transom windows.*
- ▶ *Covering transom windows with plywood.* [C]

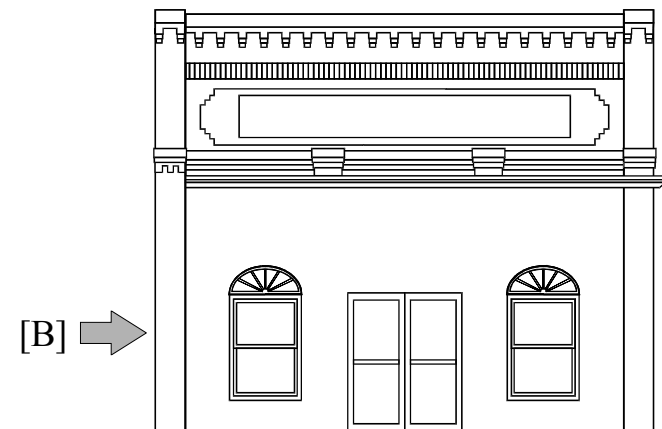
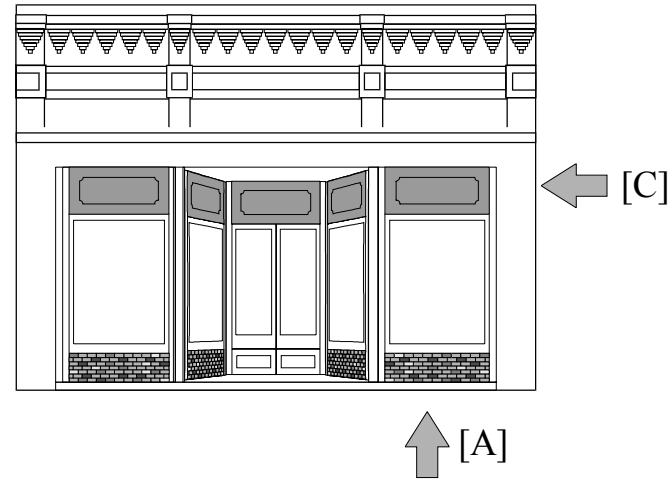

GOAL:

The primary goal is to maintain the historic windows, their design, and their placement.

Actions to achieve the goal:

- ▶ Maintain and preserve historic windows.
- ▶ Repair damaged portions of historic windows rather than replacing them in total.
- ▶ Historic windows damaged beyond repair should be replaced with windows of matching materials, design, pane configuration, and muntin profile. Aluminum clad wood windows may be allowed on upper story windows, but not windows of vinyl or aluminum construction.
- ▶ Maintain the historic window configuration and dimensions.
- ▶ New windows on side and rear elevations should relate to historic windows in the following ways:
 - a) use matching materials,
 - b) be of matching or similar size, and
 - c) use matching or similar design.
- ▶ Storm windows must match the color of the window frame and obscure the window as little as possible.



Windows refers to glazed openings in the exterior walls of the building. (see also *Storefronts*, p. 30)

Glossary terms:

Beyond repair.

When such a large portion of an element is damaged that repair becomes infeasible, generally, but not specifically, more than 50%.

Double hung window.

A window having two sashes, one sliding vertically over the other.

Fenestration.

The arrangement of window openings in a building.

Lintel.

A horizontal beam over a door or window which carries the weight of the wall above; usually made of stone or wood.

Muntin.

A secondary framing member to divide and hold the panes of glass in a window.

Sash.

The portion of a window that holds the glass and which moves.

Sill.

The horizontal member located at the top of a foundation supporting the structure above; also the horizontal member at the bottom of a window or door.

Solid-to-void.

The total area of wall in comparison to the total area of openings on an elevation.

- more terms found in the *Glossary*, p. 96

Changes requiring a COA

Examples:

- * Removing and replacing windows.
- * Filling in existing window openings.
- * Adding new window opening.
- * Adding new storm windows and screens.

Changes not requiring a COA

Examples:

- * Replacing broken window glass.
- * Repairing damaged portions of existing sashes.
- * Weather-stripping, caulking, painting and other general maintenance.
- * Adding clear UV coating.

Common Mistakes

- ▶ *Replacing viable (deteriorated but repairable) historic windows with new windows, even similar looking windows.*
- ▶ *Replacing windows with flat muntins with no profile.*
- ▶ *Replacing windows with tinted glass, single panes, or smaller windows. [A]*
- ▶ *Reducing the size of windows. [B]*
- ▶ *Infilling windows. [C]*
- ▶ *Adding storm windows which obscure the historic window.*

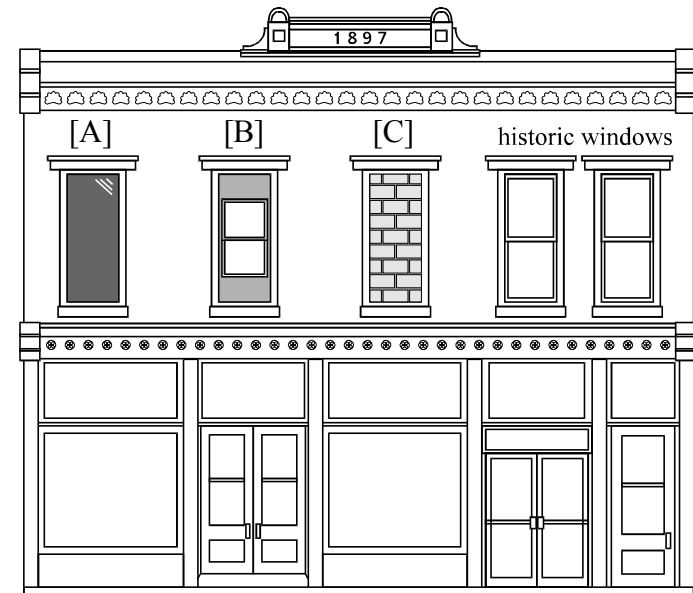

GOAL:

The primary goal is to maintain the historic doors, their design, and their placement.

Actions to achieve the goal:

- ▶ Maintain and preserve historic doors and surrounding features.
- ▶ Repair damaged portions of historic doors rather than replacing the door in total.
- ▶ Historic doors damaged beyond repair should be replaced with doors that match in material and design.
- ▶ Maintain the historic door placement on the facade including entrances to upper floors.
- ▶ Replace non-historic doors with a replication of the historic door (if documentation exists) or a design typical for the age of the building.

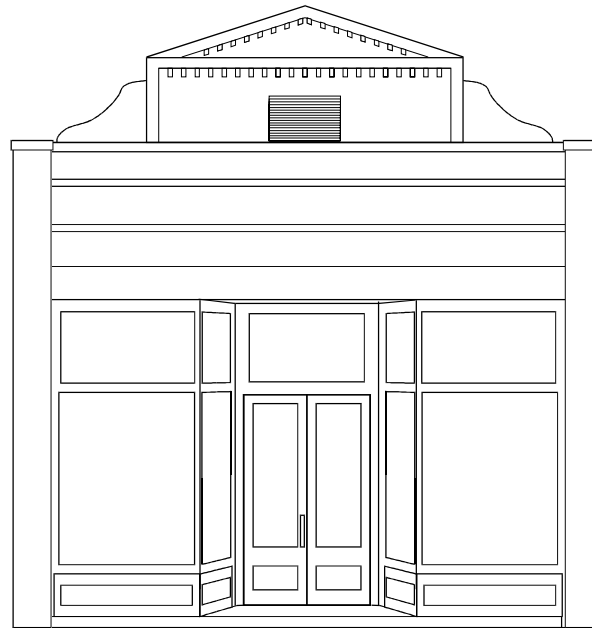

Doors refers to entrances into the building including the doorway and features around the doorway. (see also *Storefronts*, p. 30)

Glossary terms:

Beyond repair.

When such a large portion of an element is damaged that repair becomes infeasible, generally, but not specifically, more than 50%.

Facade.

The front elevation or “face” of a building.

French door.

A door made of many glass panes, usually used in pairs and attached by hinges to the sides of the opening in which it stands.

Mullion. A heavy vertical divider between windows or doors.

Pediment.

A triangular crowning element forming the gable of a roof; any similar triangular element used over windows, doors, etc.

Surround.

An encircling border or decorative frame, usually around a window or door.

Transom.

A small operable or fixed window located above a window or door.

- more terms found in the Glossary, p. 96

Changes requiring a COA

Examples:

- * Removing and replacing doors.
- * Filling in existing door openings.
- * Adding new door openings.
- * Adding new storm /screen doors.

Changes not requiring a COA

Examples:

- * Repairing damaged portions of existing doors.
- * Weather-stripping, caulking, painting and other general maintenance.

Common Mistakes

- ▶ *Replacing viable (deteriorated but repairable) historic doors with new doors, even similar looking doors.*
- ▶ *Using a door with a residential appearance. [A].*
- ▶ *Adding or removing doors on the facade.*
- ▶ *Adding sidelights, transoms, fanlights, or other features where none existed before. [B]*

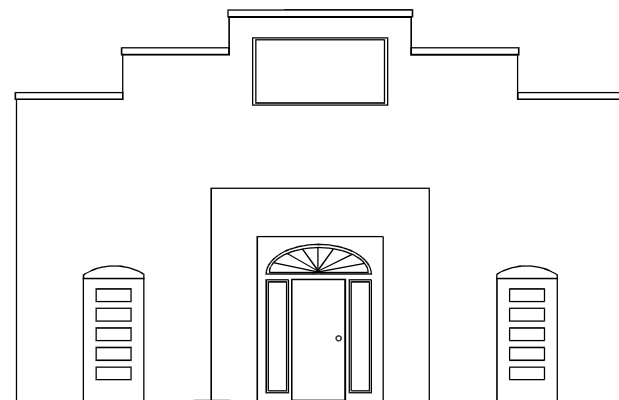

GOAL:

The primary goal is to promote the use of traditional form and design for awnings and canopies.

Actions to achieve the goal:

- ▶ Maintain historic awnings and canopies.
- ▶ Use canvas for awning materials.
- ▶ Match awnings shape to the shape of the window or door opening.
- ▶ Fit awning within the frame of the window or doorway without covering architectural detail.
- ▶ Traditional shed-style, sloping, fabric/canvas awnings are encouraged.

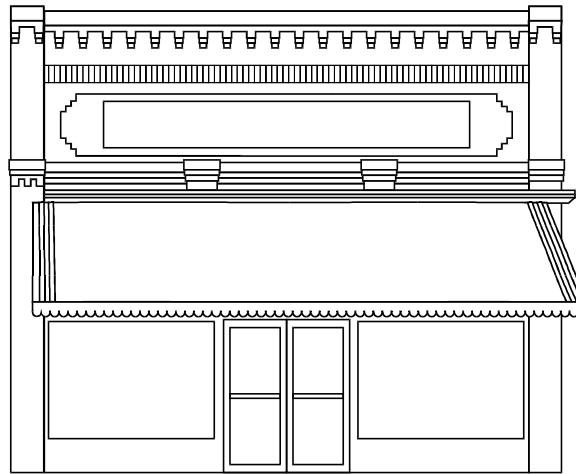

Awnings refers to elements projecting from the building which provide shade to the adjacent area. Canopies are included.

Glossary terms:

Awning.

A sloped projection supported by a frame attached to the building facade or by simple metal posts anchored to the sidewalk.

Canopy.

A flat projection from the building facade or attached to the building facade to shelter the storefront and pedestrian traffic.

Cornice.

The uppermost, projecting part of an entablature, or feature resembling it.

- more terms found in the Glossary, p. 96

Changes requiring a COA

Examples:

- * Removing awnings.
- * Adding a new awnings or canopies.

Changes not requiring a COA

Examples:

- * Replacing awning canvas.
- * Repairing a metal awning.
- * Repainting a metal awning.

Common Mistakes

- ▶ *Using a rounded awning for a rectangular doorway or window. [A]*
- ▶ *Using an awning which does not match the dimension of the doorway or window. [B]*
- ▶ *Using barrel-style awnings. [C]*
- ▶ *Using flat projecting metal or rigid plastic awnings.*
- ▶ *Lighting awnings internally.*
- ▶ *Using a continuous awning across two buildings to join them as one business. [D]*
- ▶ *Constructing a front porch and balcony where none existed before.*

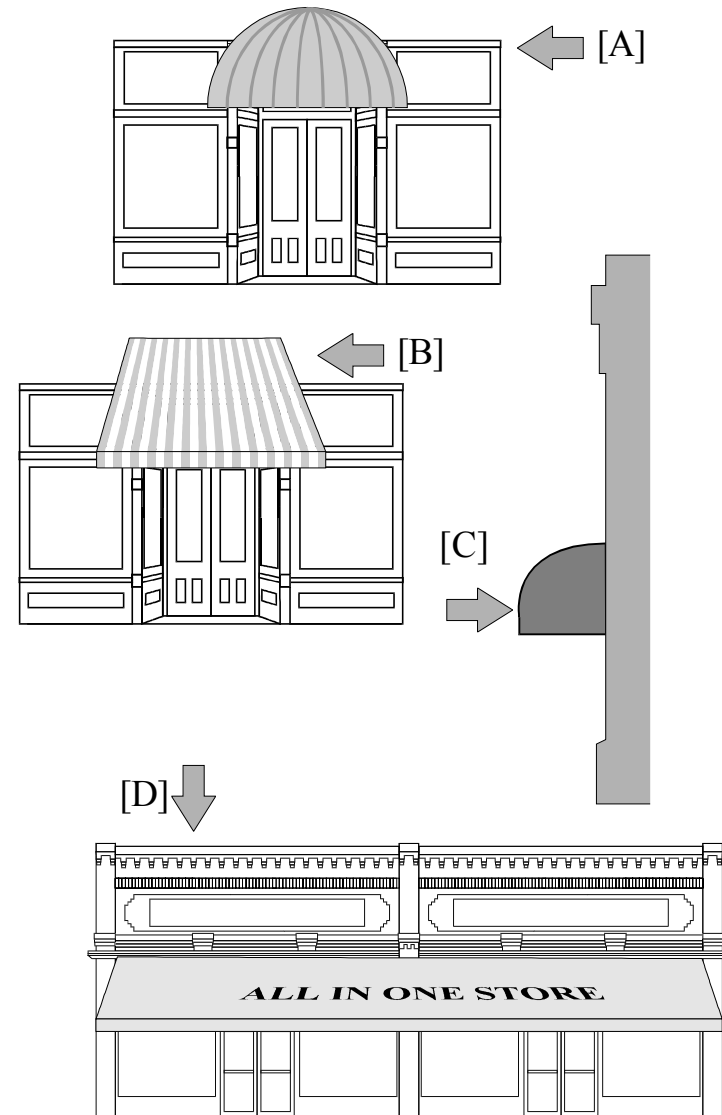

GOAL:

The primary goal is to allow expansion while maintaining historic character.

Actions to achieve the goal:

- ▶ Additions should respect the original portion of the building by:
 - a) being placed away from the public view on the rear elevation or (for buildings not on the square) on a side elevation well behind the facade,
 - b) maintaining the form, orientation, and symmetry of the original structure,
 - c) creating a discernible break at the juncture with the original structure,
 - d) using matching or similar materials such as roofing and siding,
 - e) using matching or similar elements, such as windows, on side elevations and reserving more modern elements for the rear elevation,
 - f) using a degree of ornamentation equal to the original or less, and
 - g) being reversible with a limited loss of historic materials and elements.

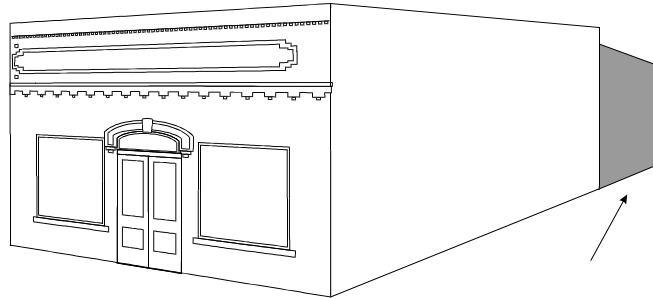

additions are best placed at the rear of the building

Additions refers to any increase in the square footage of a building.

Glossary terms:

Elevation.

Any of the external faces of a building.

Facade.

The front elevation or “face” of a building.

Public view.

That which can be seen from any public right-of-way.

Reversible.

Constructing additions or new elements in such a manner that if removed in the future original form and material would be largely unchanged.

Routine maintenance.

Any action performed in order to preserve a historic property including minor replacement of material with like material providing no change is made to the appearance of the structure or grounds.

Orientation.

The direction that the building (usually includes the primary entrance) faces.

- more terms found in the Glossary, p. 96

Changes requiring a COA
Examples:

- * Adding an addition to a building.
- * Removing an addition from a building.

Changes not requiring a COA
Examples:

- * Routine maintenance to existing additions.

Common Mistakes

- ▶ *Constructing the walls of the addition flush with the facade of the original structure. [A]*
- ▶ *Constructing an addition out of scale which greatly alters the original form of the building.*
- ▶ *Using incompatible materials or details on an addition. [B]*
- ▶ *Removing a large amount of original material to add an addition.*

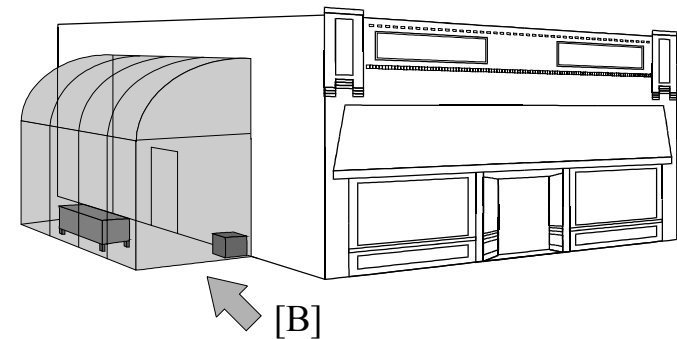
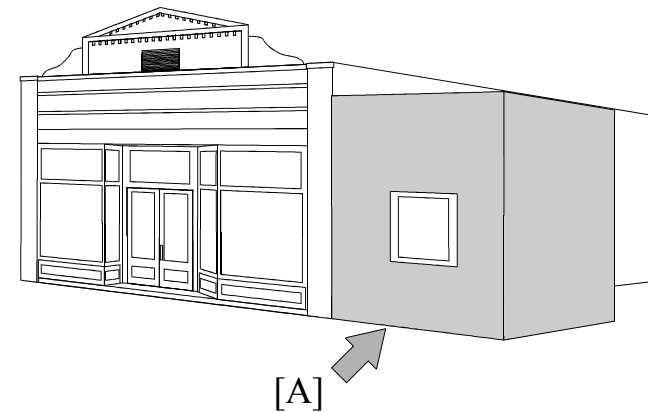

40 NEW CONSTRUCTION PLACEMENT

GOAL:

The primary goal is to follow the distinct rhythm established by the placement pattern of historic buildings in the district.

Actions to achieve the goal:

- ▶ New buildings should respect the placement of nearby historic buildings by being:
 - a) placed at a setback equal to or within 10 feet of that of nearby similar historic buildings or similar buildings within the district,
 - b) placed centrally on a lot with equal spacing on each side (party walls for buildings on the square), and
 - c) oriented towards (or facing) the same street as nearby historic buildings.

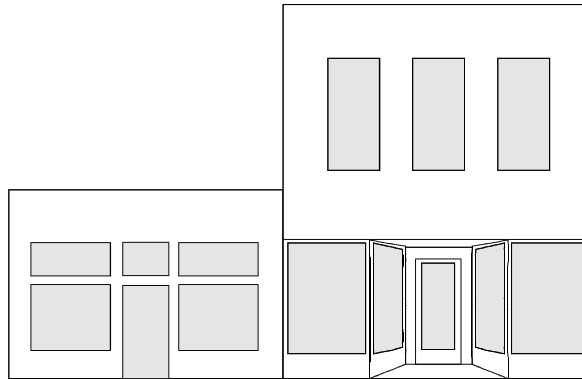

Downtown buildings are placed at the front of their lots (zero lot line) and share side walls with adjacent buildings (party walls).

Placement refers to how the building is located or situated upon its lot. Placement includes building setback, spacing, and orientation.

Glossary terms:

Nearby historic buildings.

The closest possible examples: 1) adjacent historic buildings, 2) historic buildings along the same street, 3) historic buildings within the immediate area, 4) historic buildings within the district.

Orientation.

The direction that the building (usually includes the primary entrance) faces.

Party wall.

A common, shared wall between two buildings; typical of downtown brick buildings.

Rhythm.

The pattern created by the relationship of elements along a street or on individual buildings (e.g. buildings to the open space or windows to wall space).

Setback.

A term used to define the distance a building is located from a street or sidewalk.

Spacing.

The distance between adjacent buildings.

- more terms found in the Glossary, p. 96

Notes/Revisions:

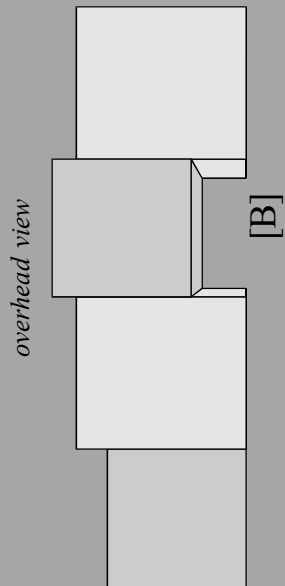
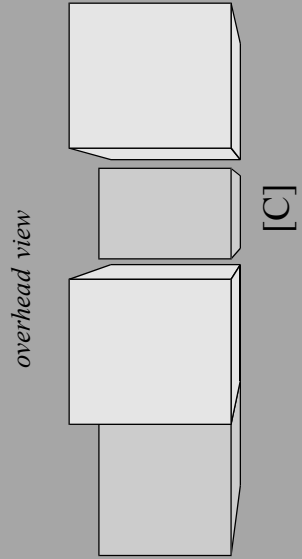

Common Mistakes

- ▶ Placement of a building facing a different street; corner or dual frontage properties should follow the example set by nearby historic corner properties. [A]
- ▶ Placement of a building not on the front lot line. [B]
- ▶ Placement of a building with side setbacks not party walls. [C]

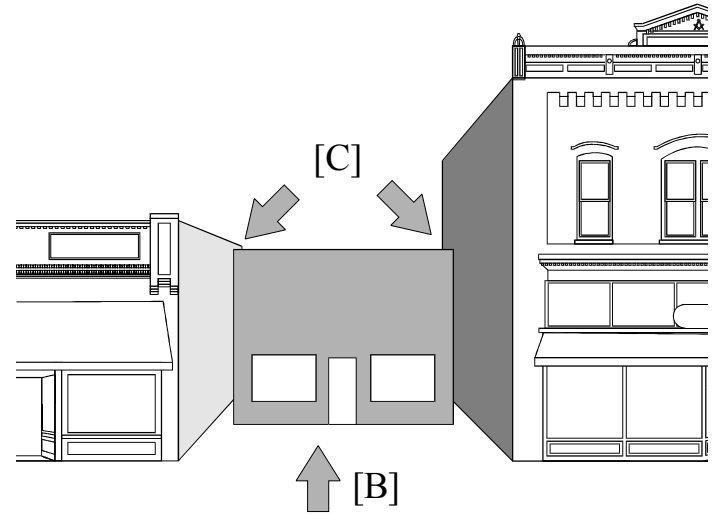
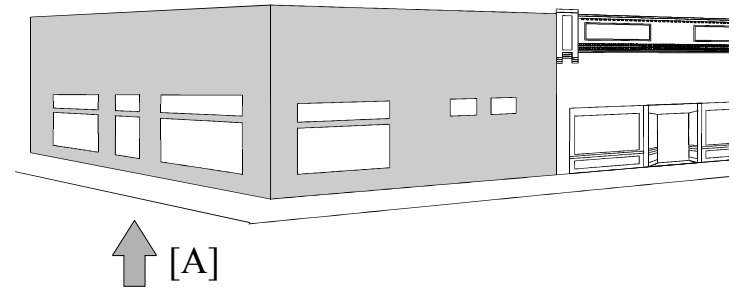

42 NEW CONSTRUCTION SCALE

GOAL:

The primary goal is to follow the established dimensions of historic buildings within the district.

Actions to achieve the goal:

- ▶ New buildings should respect the existing scale of historic buildings by being:
 - a) either one-story or two-story depending upon the uniformity of height displayed by nearby historic buildings,
 - b) approximately the same width as nearby historic buildings of similar form, and
 - c) approximately the same depth of nearby historic buildings; for more depth, new buildings should follow the addition pattern of nearby historic buildings of similar scale.

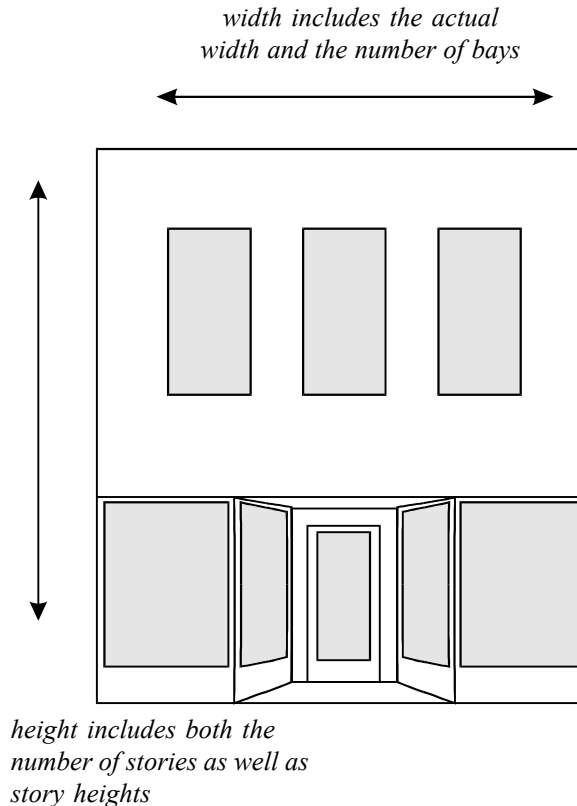

Scale refers to a building's dimensions - height, width, and depth - particularly in comparison to other buildings in the vicinity.

Glossary terms:

Bay.

The horizontal divisions of a building, defined by windows, columns, pilasters, etc.

Nearby historic buildings.

The closest possible examples: 1) adjacent historic buildings, 2) historic buildings along the same street, 3) historic buildings within the immediate area, 4) historic buildings within the district.

- more terms found in the Glossary, p. 96

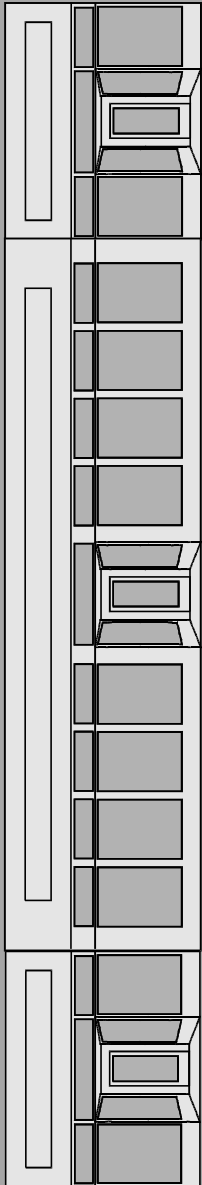

[C]

Common Mistakes

- ▶ *Constructing a building of more than two stories.*
[A]
- ▶ *Constructing a building out of scale with its neighbors even though the number of stories is equal.*
[B]
- ▶ *Constructing a building that is too wide and creates an inappropriate horizontal appearance.*
[C]

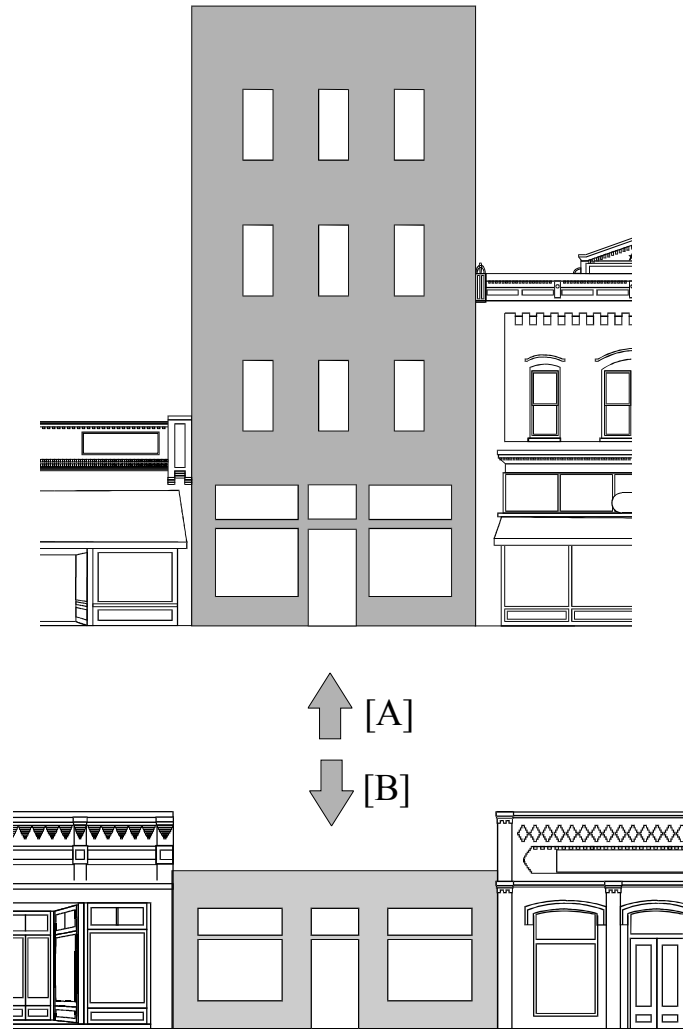

44 NEW CONSTRUCTION FORM

GOAL:

The primary goal is to follow the unique pattern of building forms found within the historic district.

Actions to achieve the goal:

- ▶ New buildings should respect the existing form represented among historic buildings by:
 - a) using roof shapes, pitches, and parapets such as those on nearby similar historic buildings or similar buildings within the district,
 - b) creating a main block and using secondary blocks in a manner similar to that of nearby similar historic buildings or similar buildings within the district, and
 - c) having foundations of the similar height and pattern as similar historic buildings.

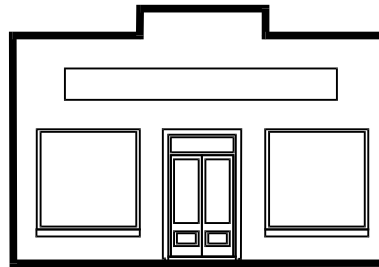

From the front each building creates a silhouette. On blueprints, this known as an "elevation."

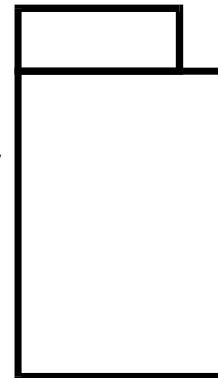

Each building creates a "footprint" created by the exterior walls of the building. On blueprints, this is called the "plan" or "floor plan."

Form refers to a building's overall shape and composition. Vertically there are three divisions of form: the roof, the body, and the foundation.

Glossary terms:

Main block.

The central mass of a building, generally excluding secondary blocks such as additional wings, projections, dormers, or porches.

Nearby historic buildings.

The closest possible examples: 1) adjacent historic buildings, 2) historic buildings along the same street, 3) historic buildings within the immediate area, 4) historic buildings within the district.

Pitch. A term which refers to the steepness of roof slope.

Secondary blocks. Portions of the building attached to the central mass of a building, generally such as additional wings, projections, dormers, or porches.

- more terms found in the Glossary, p. 96

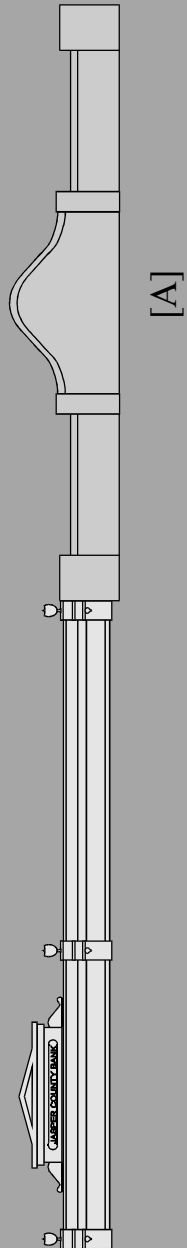

Common Mistakes

- ▶ *Constructing a parapet with a form or style atypical to the area. [A]*
- ▶ *Constructing a building with secondary blocks rather than one main block. [B]*
- ▶ *Constructing a building with a roof form unlike the established pattern. [C]*

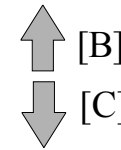
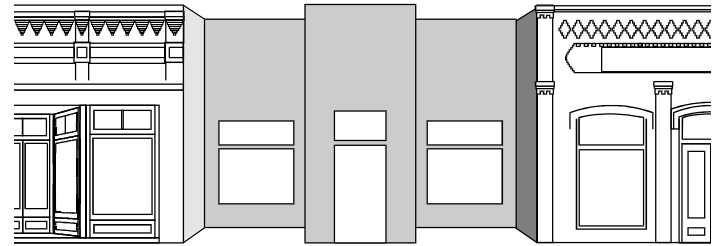

GOAL:

The primary goal is to follow the solid-to-void ratio characteristic of historic buildings in the district.

Actions to achieve the goal:

- ▶ New buildings should respect the pattern of openings on historic buildings by:
 - a) using openings of similar dimensions and shape,
 - b) placing or distributing openings in a manner similar to that of nearby similar historic buildings or similar buildings within the district, and
 - c) balancing the ratio of solid-to-void by using the appropriate amount of opening on an elevation.

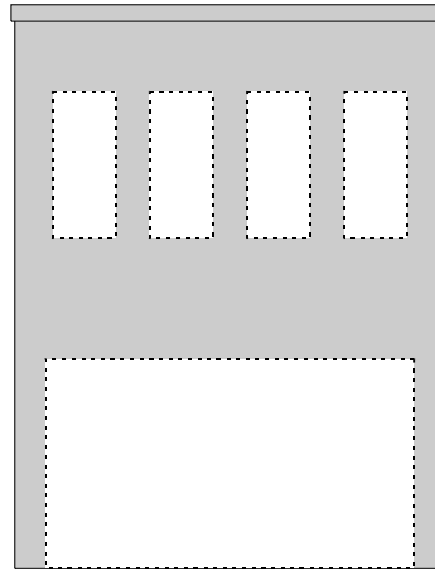

Downtown commercial buildings have a high degree of void at street level and evenly spaced smaller voids on upper floors.

Openings refers to windows and doors. Void is another term for openings.

Glossary terms:

Elevation.

Any of the external faces of a building.

Facade.

The front elevation or “face” of a building.

Nearby historic buildings.

The closest possible examples: 1) adjacent historic buildings, 2) historic buildings along the same street, 3) historic buildings within the immediate area, 4) historic buildings within the district.

Solid-to-void.

The total area of wall in comparison to the total area of openings on an elevation.

- more terms found in the Glossary, p. 96

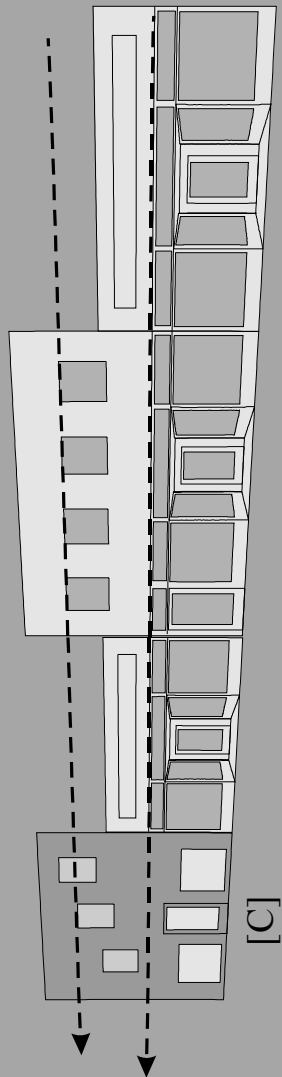

Common Mistakes

- ▶ Using an asymmetrical distribution of windows and doors when symmetrical facades are the established pattern within that block. [A]
- ▶ Using a high solid-to-void ratio at ground level (the storefront) or a low solid-to-void ratio on upper floors. [B]
- ▶ Failing to align openings with other buildings on the same block. [C]

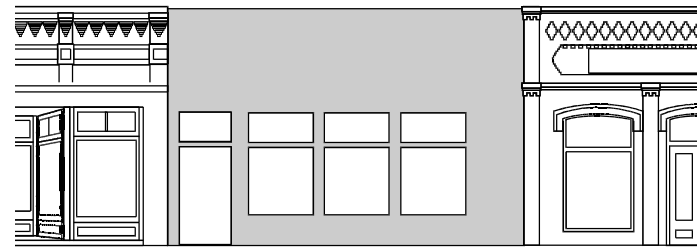

GOAL:

The primary goal is to follow the pattern of use of materials within the historic district.

Actions to achieve the goal:

- ▶ New buildings should respect the historic materials within the district by using the predominant exterior material - namely brick.
- ▶ New buildings should respect the ornamentation within the district by:
 - a) using ornamentation in a manner similar to that of nearby similar historic buildings or similar buildings within the district, and
 - b) using ornamentation to a degree equal to or less than that of nearby similar historic buildings or similar buildings within the district.

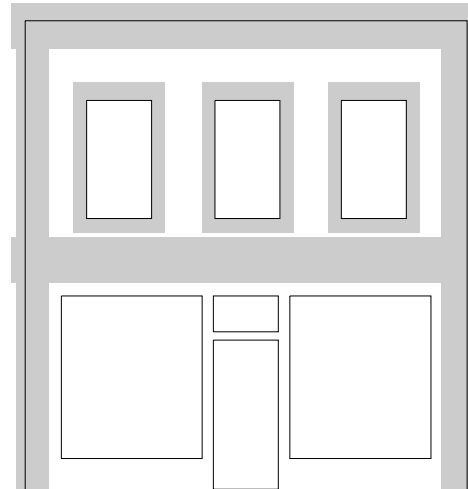

Shaded areas are traditional locations of ornament on commercial buildings.

Materials refers to the composition, texture, and appearance of the exterior surface of a building. **Details** refers to ornamentation that embellish the building.

Glossary terms:

Facade.

The front elevation or “face” of a building.

Nearby historic buildings.

The closest possible examples: 1) adjacent historic buildings, 2) historic buildings along the same street, 3) historic buildings within the immediate area, 4) historic buildings within the district.

Solid-to-void.

The total area of wall in comparison to the total area of openings on an elevation.

Synthetic stucco (EIFS).

Exterior insulation and finish systems (EIFS) are multi-component exterior wall systems which generally consist of: an insulation board; a base coat reinforced with glass fiber mesh ; and a finish coat.

Variiegated brick.

Multi-colored brick used in an attempt to create an antique look.

- more terms found in the Glossary, p. 96

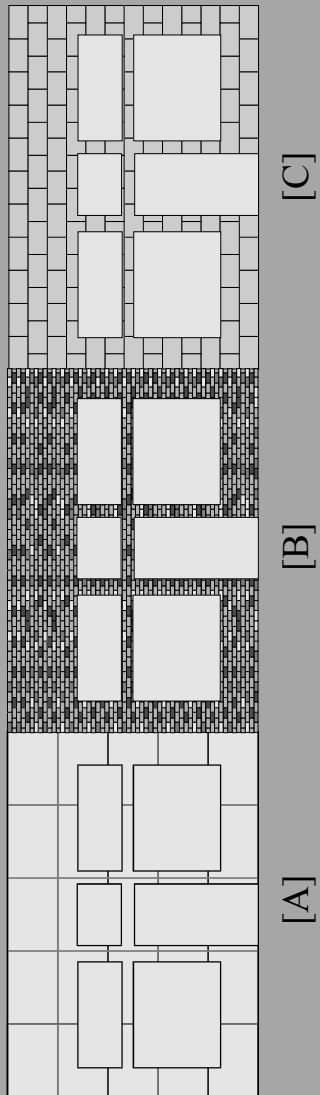

Common Mistakes

- ▶ *Using synthetic stucco (E.I.F.S.) [A]*
- ▶ *Using variegated brick . [B] or concrete block. [C]*
- ▶ *Using any material other than brick.*
- ▶ *Copying historic styles or themes not common to the area such as colonial or wild west. [D]*
- ▶ *Use of stock details which do not match the proportions and degree of craftsmanship of historic details.*

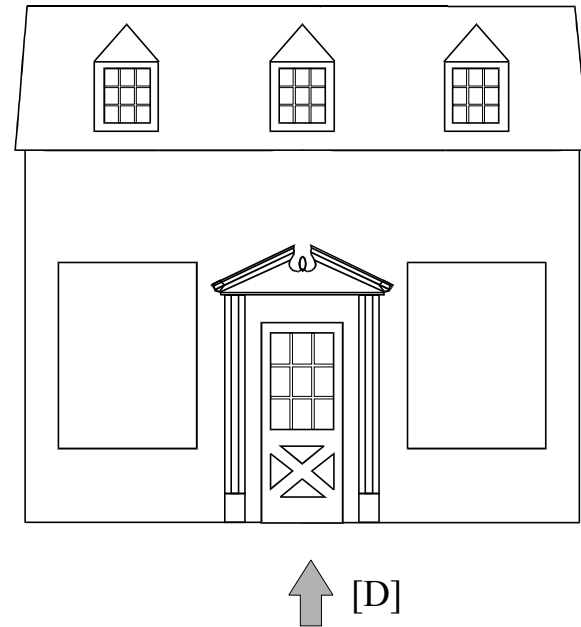

WALLS & FENCES

GOAL:

The primary goal is to maintain the pattern of fencing in the commercial area and to use fencing and walls to screen parking and storage areas.

Actions to achieve the goal:

- ▶ Historic fences and retaining walls should be maintained and not removed.
- ▶ New security fences should limit their impact by:
 - a) being placed behind the rear elevation, being no taller than 8 feet in height, and
 - b) using traditional materials (in most cases wood) or screening fence from the public view with evergreen vegetation or a second traditional fence.
- ▶ New screening walls can be used to limit the impact of parking on the district by:
 - a) being of a height to partially screen parked vehicles;
 - b) replicating the facade line of nearby historic buildings; and
 - c) using traditional materials (in most cases brick).

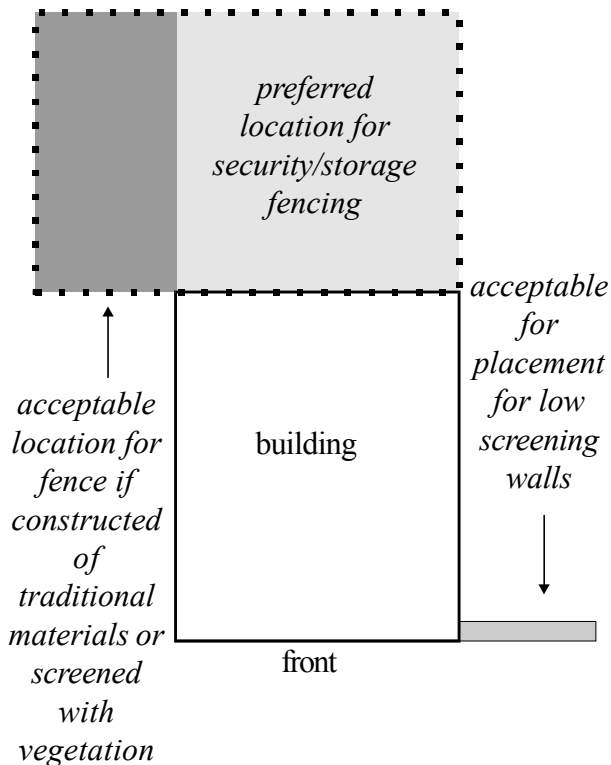

Walls and fences refers to nonvegetative elements used in and around a property for safety, security, and screening.

Glossary terms:

Elevation.

Any of the external faces of a building.

Evergreen vegetation.

Vegetation which retains foliage through the winter months maintaining its screening property.

Facade line.

An imaginary line established by the fronts of buildings on a block.

- more terms found in the Glossary, p. 96

Changes requiring a COA

Examples:

- * Construction of a new fence.
- * Construction of a new screening wall.

Common Mistakes

- ▶ *Using nontraditional materials, such as metal chainlink, for fences in the public view. [A]*
- ▶ *Placing a privacy fence flush with the facade of a building. [B]*

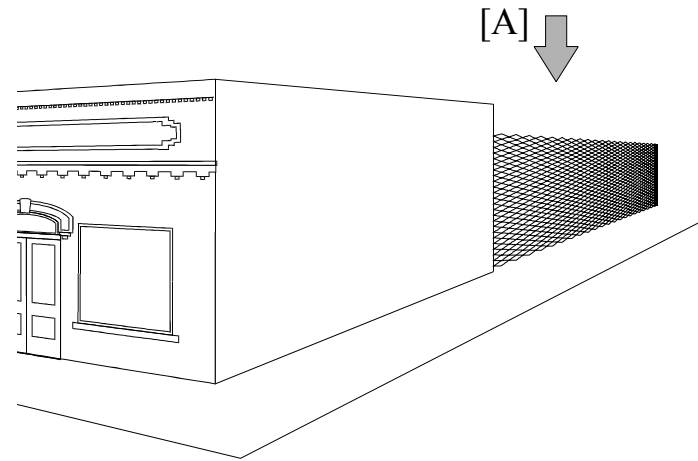

Changes not requiring a COA

Examples:

- * Repair of an existing fence.
- * Painting an existing fence.
- * Repair of an existing wall.
- * Temporary fences at construction sites.



MODERN FEATURES

GOAL:

The primary goal is to integrate modern features while limiting the negative impact to the historic district.

Actions to achieve the goal:

- ▶ Mechanical systems placed behind the building and out of the public view.
- ▶ Rooftop mechanical systems, utility meters and security lighting should be placed unobtrusively.
- ▶ New lighting should use traditional designs appropriate to the character of the building.
- ▶ New parking should:
 - a) be placed as unobtrusively as possible;
 - b) use traditional materials: gravel, concrete, stone pavers, though asphalt is allowed in the downtown; and
 - c) use appropriate screening (see *Walls & Fences* p. 50).

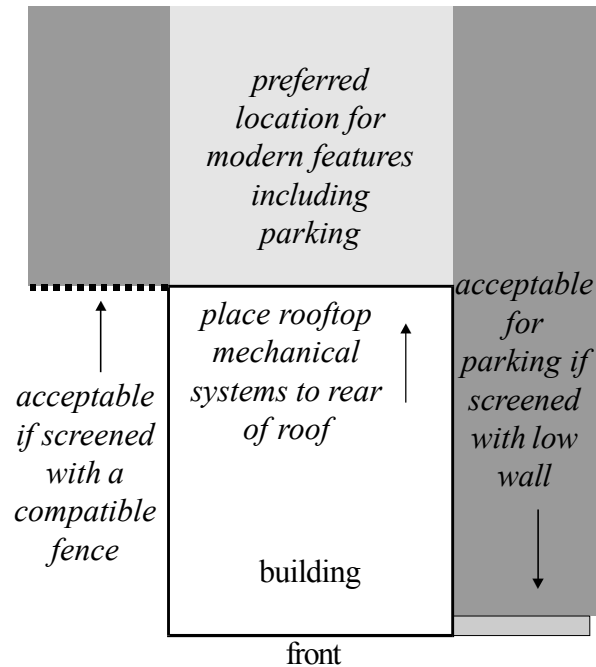

Modern features refers to equipment and functions not used in the past such as dumpsters, fire escapes, mechanical systems, and parking areas.

Glossary terms:

Facade line.

An imaginary line established by the fronts of buildings on a block.

Parking.

Areas, generally paved, provided for the storage of automobiles.

Paving.

Any material used for pavement such as asphalt, brick, concrete, gravel, or pavers.

Public view.

That which can be seen from any public right-of-way.

- more terms found in the *Glossary*, p. 96

Notes/Revisions:

Changes requiring a COA

Examples:

- * Adding parking areas.
- * Placing exterior mechanical systems such as satellite dishes, air-conditioning units, or utility meters.
- * Adding exterior lighting.

Common Mistakes

- ▶ *Demolishing historic buildings for parking (see demolition p.).*
- ▶ *Failing to screen parking from the public view (see Fences & Walls, p. 48) [A]*
- ▶ *Placing mechanical systems to the front of rooftops. [B]*



[A]

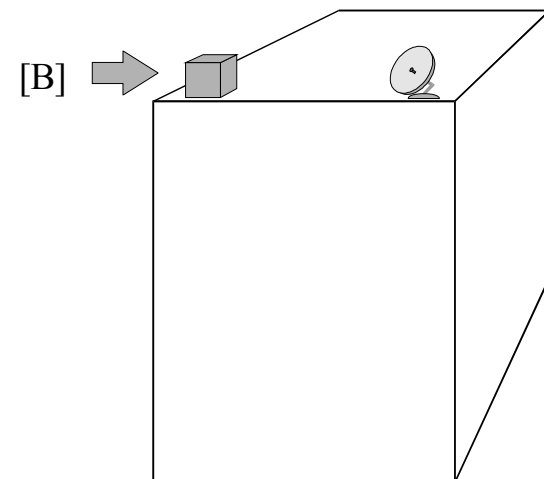

[B]

Changes not requiring a COA

Examples:

- * Resurfacing an existing parking area with the same material.
- * Interior changes to mechanical systems.
- * Temporary event lighting.

GOAL:

The primary goal is to create signs which both inform the public and compliment the property where they are located.

Actions to achieve the goal:

- ▶ Historic signs should be maintained and preserved
- ▶ Signs must conform to the City of Acworth sign ordinance and are to be approved on a case by case basis in the Historic Business District (HBD) through a formal review by one representative of HPC, DDA, and City staff.
- ▶ Signs should:
 - a) be limited in number to the minimum necessary for identification purposes,
 - b) use traditional sign locations,
 - c) be of a scale appropriate to the building and the district,
 - d) be painted wood or metal,
 - e) have little ornament or use ornament similar to the style of the building, and
 - f) avoid attachment to roofs or covering architectural details.

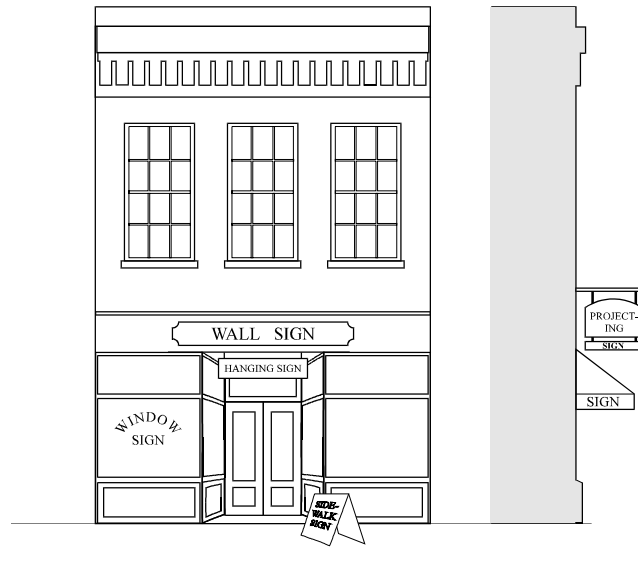

Signs refers to permanent signs for business identification, advertisement, and operation.

Glossary terms:

Cast iron front.

A storefront made of glass and pieces of utilitarian and decorative iron cast in easily assembled parts.

Corbeling.

A series of stepped or overlapped pieces of brick or stone forming a projection from the wall surface.

Cornice.

The uppermost, projecting part of an entablature, or feature resembling it.

Recessed panel.

A decorative element that often functions as an area for signage.

Transom.

A small operable or fixed window located above a window or door.

- more terms found in the Glossary, p. 96

Changes requiring a COA

Examples:

- * Placing a new sign on a building or property.

Changes not requiring a COA

Examples:

- * Placing temporary signs such as event, political, or real estate signs (as allowed under the City of Acworth sign ordinance).

Common Mistakes

- ▶ *Using more than two signs per building.*
- ▶ *Using internally lit plastic signs.*
- ▶ *Using unfinished wood, plastic substrate, or plywood signs.*
- ▶ *Using inappropriately large signs. [A]*
- ▶ *Using signs with a colonial motif. [B]*
- ▶ *Covering architectural details such as the cornice. [C]*
- ▶ *Painting over or stripping historic painted signs.*

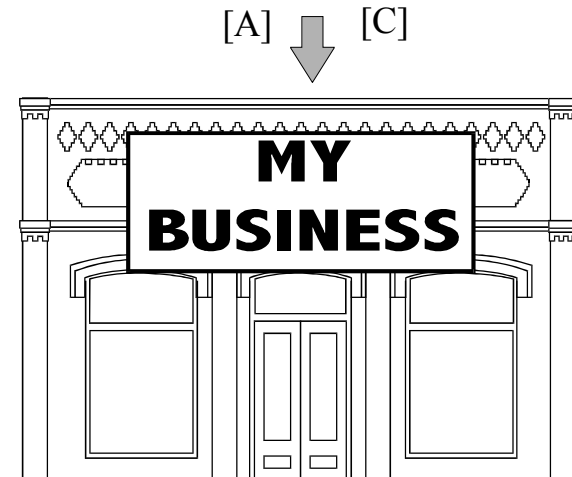



RESIDENTIAL CONTENTS

Topics/Issues

Rehabilitation

[PG 58-75] Reviews the elements of historic construction that contribute to architectural style and building form for residential properties and areas. Highlights common mistakes to avoid and provides examples of changes subject to the design review process.

Roofs - Shape & Dormers

Roofs - Materials & Features

Materials

Foundations

Details

Windows

Doors

Porches

Additions

New Construction

[PG 76-83] Discusses the most significant aspects of new construction and its relationship to and potential impact upon the existing built environment for residential properties and areas. Highlights common mistakes to avoid.

Placement

Scale & Form

Openings

Materials

Details

Site & Setting

[PG 84-95] Outlines the accessory features commonly located on historic properties and reviews their relationship to the historic building for residential properties and areas. Highlights common mistakes to avoid and provides examples of changes subject to the design review process.

Walls & Fences

Walks & Drives

Modern Features

Outbuildings

Signs

Access

GOAL:

The primary goal is to maintain the original form of the house, especially as seen from the public view.

Actions to achieve the goal:

- ▶ Maintain the existing pitch and shape of the roof.
- ▶ Maintain the shape and style of historic dormers.
- ▶ Place new dormers on the rear roof slope out of the public view.
- ▶ Place skylights on the rear roof slope out of the public view. Use skylights with a flat profile, not “bubble” skylights.

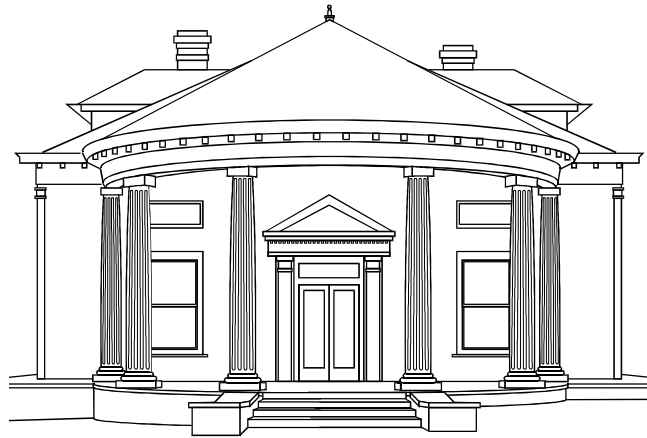

Roof shape refers to the overall roof type, its pitch, as well as any secondary roof forms. Dormers are roofed windows projecting from the slope of the main roof.

Glossary terms:

Facade.

The front elevation or “face” of a building.

Pitch.

A term which refers to the steepness of roof slope.

Public view.

That which can be seen from any public right-of-way.

Routine maintenance.

Any action performed in order to preserve a historic property including minor replacement of material with like material providing no change is made to the appearance of the structure or grounds.

- more terms found in the Glossary, p. 96

Changes requiring a COA

Examples:

- * Changing the pitch or shape of a roof.
- * Altering the shape of a dormer.
- * Addition of a dormer.
- * Removal of a dormer.
- * Adding a skylight.

Changes not requiring a COA

Examples:

- * Routine maintenance to dormers.

Common Mistakes

- ▶ *Placing a new dormer on the facade of a house where none has existed before. [A]*
- ▶ *Changing the shape of a roof in order to gain upstairs space. [B]*
- ▶ *Changing a historic dormer's shape.*
- ▶ *Placing skylights on a front roof slope.*

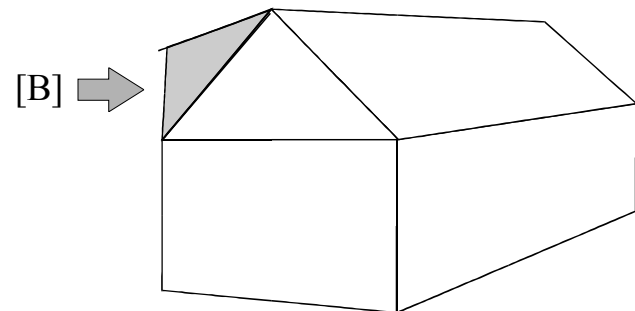

GOAL:

The primary goal is to maintain the texture and silhouette created by historic roofing materials and features.

Actions to achieve the goal:

- ▶ Replace roofing materials with those that: match the existing, replicate the original materials, more closely match the original, or are typical for the age, style, and form of the house.
- ▶ Maintain hidden gutters or eaves designed without gutters whenever possible.
- ▶ Maintain historic chimneys.
- ▶ Rebuild documented missing chimneys whenever possible.
- ▶ New chimneys (including chimneys on additions) should:
 - a) be placed on the rear or toward the rear on side elevations,
 - b) use traditional design, and
 - c) be brick.

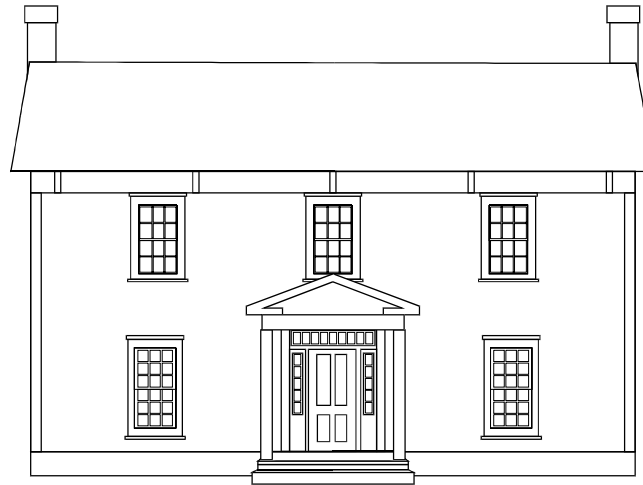

Roof materials refers to the material with which the roof is sheathed. Roof features are any items attached to the roof whether functional or ornamental.

Glossary terms:

Character defining.

An element whose design and material is associated with the age and style of a building and helps define its architectural style (e.g. pressed tin roofing on Victorian era buildings).

Flashing.

Thin metal sheets used to make the intersections of roof planes and roof/wall junctures watertight.

Finial.

A projecting decorative element at the top of a roof, turret or gable.

- more terms found in the Glossary, p. 96

Changes requiring a COA

Examples:

- * Reroofing a roof with a material which is different than the existing material.
- * Removing or adding chimneys.
- * Stuccoing brick chimneys.
- * Adding roof vents.
- * Adding gutters where none exist.

Changes not requiring a COA

Examples:

- * Reroofing a roof with a material which is different than the existing material.
- * Removing or adding chimneys.
- * Stuccoing brick chimneys.
- * Adding roof vents.
- * Adding gutters where none exist.

Common Mistakes

- ▶ *Replacing character defining roofing materials (e.g. pressed metal shingles) with another material.*
- ▶ *Removing chimneys. [A]*
- ▶ *Adding modern-looking, false chimneys. [B]*
- ▶ *Using contemporary metal roofing systems on residences where metal roofs are inappropriate for the style or age of the house, for example: high style Queen Anne houses or post-WWII structures such as ranch houses.*

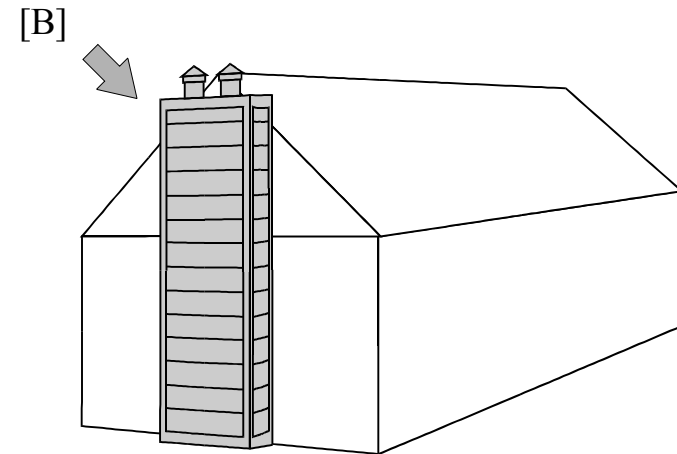
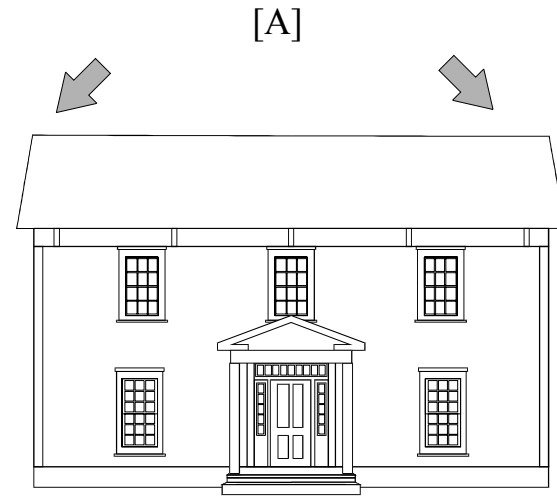

GOAL:

The primary goal is to maintain the texture created by historic exterior materials.

Actions to achieve the goal:

- ▶ Maintain historic siding.
- ▶ Leave unpainted masonry unpainted and uncoated.
- ▶ Repair damaged siding or replace with in-kind material and only in the area of damage (rather than completely replacing the siding).
- ▶ Use a historic mortar mix [see right] and match the original mortar joints when repointing brick. Use a qualified professional mason.
- ▶ Use the gentlest means possible to clean exterior materials.

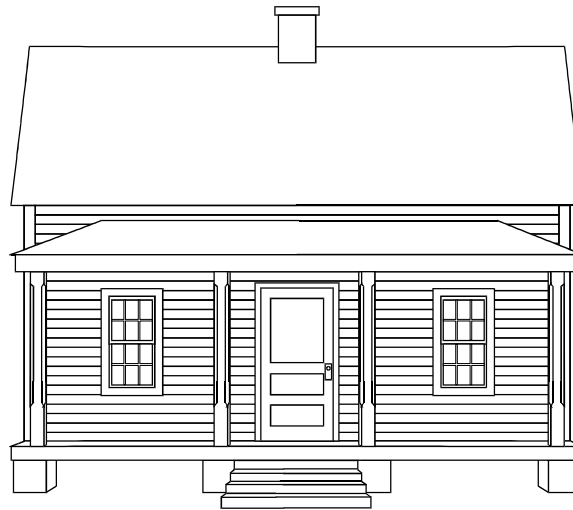

Materials, in this instance, refers to the material with which the exterior walls of the house are covered.

Glossary terms:

Bond.

A term used to describe the various patterns in which brick is laid.

Gentlest means possible.

The least abrasive, intrusive, damaging means of preserving historic material.

Historic mortar mix.

There are designated five mortar types. Typically, the repointing mortar for historic buildings will be a Type O or K mortar. Mortar specifications permit a range of proportions, but typical proportions by volume are: Type O - 1 part portland cement, 2 parts hydrated lime, and 9 parts sand; Type K - 1 part portland cement, 4 parts hydrated lime and 15 parts sand.

In-kind.

Using the exact same material when replacing a damaged element (e.g. using a wood element to replace a wood element).

Reveal.

The vertical profile created by the lap of siding, window casings, muntins, door surrounds, etc.

Siding. The exterior wall covering or sheathing of a structure.

- more terms found in the Glossary, p. 96

Changes requiring a COA

Examples:

- * Removing siding material.
- * Residing a building.
- * Painting unpainted masonry.
- * Entirely removing paint from a building.
- * Repointing of brick.

Changes not requiring a COA

Examples:

- * Repainting a building.
- * Preparing surfaces for repainting.

Common Mistakes

- ▶ *Placing vinyl or aluminum siding, EIFS (synthetic stucco), or any other type of synthetic siding on a historic house rather than maintaining and repairing the existing exterior materials.*
- ▶ *Adding brick veneer to a house. [A]*
- ▶ *Sandblasting exterior surfaces.*
- ▶ *Painting or “waterproof” coating unpainted masonry.*

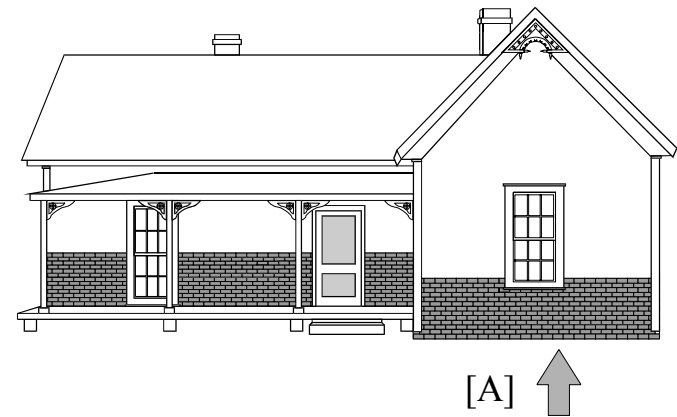

GOAL:

The primary goal is to maintain the original design of the foundation.

Actions to achieve the goal:

- ▶ Maintain the original design and materials of the foundation.
- ▶ Maintain open pier foundations of the main structure whenever possible.
- ▶ Always leave porch pier foundations open or infill with wood lattice or vertical wood slats.
- ▶ Pier foundations (excluding porches) may be infilled if:
 - a) the infill material is recessed from the piers,
 - b) the infill is skim coated with stucco,
 - c) the infill is painted a dark color, and
 - d) vents are installed at regular intervals.
- ▶ Leave unpainted historic masonry foundation materials unpainted.
- ▶ Use a historic mortar mix [see right] and match the original mortar joints when repointing brick. Use a qualified professional mason.



Foundation refers to the structure on which the house rests and which anchors the house to the ground.

Glossary terms:

Historic mortar mix.

There are designated five mortar types. Typically, the repointing mortar for historic buildings will be a Type O or K mortar. Mortar specifications permit a range of proportions, but typical proportions by volume are: Type O - 1 part portland cement, 2 parts hydrated lime, and 9 parts sand; Type K - 1 part portland cement, 4 parts hydrated lime and 15 parts sand.

Pier.

A vertical structural element, square or rectangular in cross section.

- more terms found in the Glossary, p. 96

Changes requiring a COA

Examples:

- * Rebuilding foundations.
- * Placing material between pier foundations.
- * Painting unpainted foundations.
- * Stuccoing foundations.

Changes not requiring a COA

Examples:

- * Repainting foundations.
- * Repointing brick foundations.
- * Repairing infill material between pier foundations.

Common Mistakes

- ▶ *Infilling porch foundations with solid fill.* [A]
- ▶ *Using concrete block between piers without a skim coat of stucco or painting it a dark color.* [B]
- ▶ *Not recessing infill between piers.* [C]
- ▶ *Painting unpainted, historic, masonry foundations.*

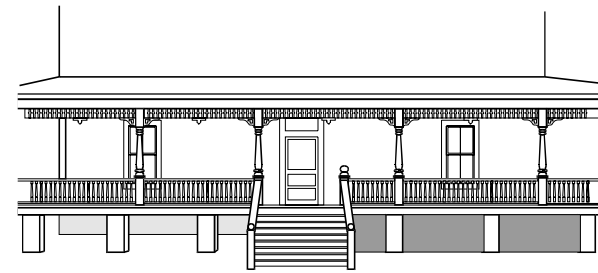

↑ [A]

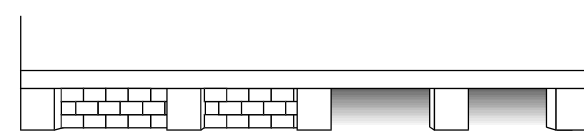

↑ [B]

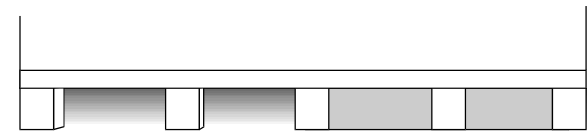

↑ [C]

GOAL:

The primary goal is to maintain detail elements typical to historic houses, many of which impart a specific architectural style.

Actions to achieve the goal:

- ▶ Maintain and preserve historic details.
- ▶ Replace damaged details with details of matching material and matching design.
- ▶ Restore missing details when documentation of those elements are available.



Details refers to those components on the exterior of the house which serve to embellish the structure often related to a specific architectural style.

Glossary terms:

Bracket.

A decorative support feature located under eaves or overhangs.

Capital.

Topmost member of a column or pilaster.

Cornice.

The uppermost, projecting part of an entablature, or feature resembling it.

Dentil.

One of a series of small, square, tooth or block-like projections forming a molding.

Documentation.

Evidence of missing elements or configurations of buildings such as architectural plans, historic photographs, or “ghosts” of missing elements.

Fascia.

A projecting flat horizontal member or molding; forms the trim of a flat

Pilaster.

A pier attached to a wall, often with capital and base.

- more terms found in the Glossary, p. 96

Changes requiring a COA

Examples:

- * Removing architectural details.
- * Adding architectural details.

Changes not requiring a COA

Examples:

- * Repairing architectural details.
- * Repainting architectural details.

Common Mistakes

- ▶ *Adding architectural details where none existed before.*
- ▶ *Removing details from a house. [A]*
- ▶ *Using stock, out of scale details rather than matching the original details. [B]*

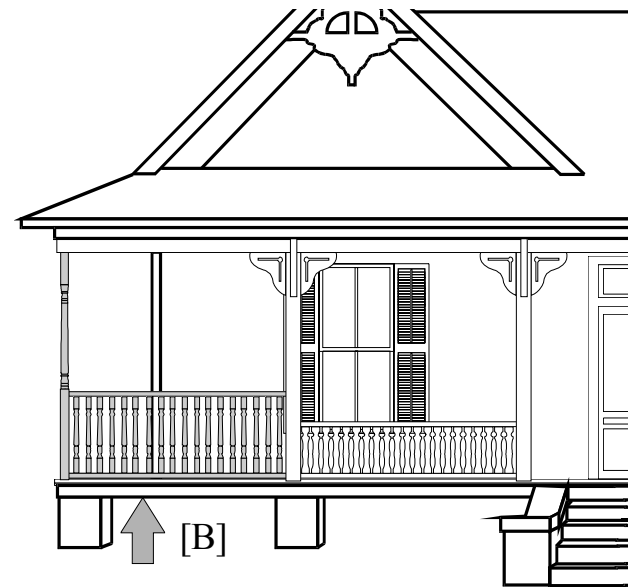

GOAL:

The primary goal is to maintain the historic windows, their design, and placement.

Actions to achieve the goal:

- ▶ Maintain and preserve historic windows – repair damaged portions of windows rather than replacing them in total.
- ▶ Historic windows damaged beyond repair should be replaced with windows of matching size, materials, pane configuration, and muntin profile. Aluminum clad wood windows may be allowed in some instances.
- ▶ Maintain or restore the historic window configuration on the facade.
- ▶ New windows on side and rear elevations should relate to historic windows in the following ways:
 - a) use matching materials,
 - b) be of matching or similar size, and
 - c) use matching or similar design.
- ▶ Only use storm windows which match the color of the window frame and hide the window as little as possible.

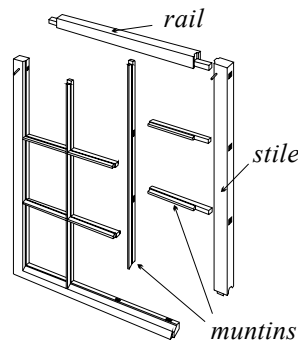

Replace only deteriorated sections rather than the entire window.

Section of historic muntin.

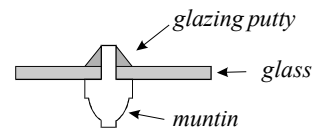

Windows refers to glazed openings in the exterior walls of the building.

Glossary terms:

Beyond repair.

When such a large portion of an element is damaged that repair becomes infeasible, generally, but not specifically, more than 50%.

Double hung window.

A window having two sashes, one sliding vertically over the other.

Fanlight.

An semicircular or semi-elliptical window with radiating muntins suggesting a fan.

Fenestration.

The arrangement of window openings in a building.

Lintel.

A horizontal beam over a door or window which carries the weight of the wall above; usually made of stone or wood.

Muntin.

A secondary framing member to divide and hold the panes of glass in a window.

Sash.

The portion of a window that holds the glass and which moves.

Sill.

The horizontal member located at the top of a foundation supporting the structure above; also the horizontal member at the bottom of a window or door.

Solid-to-void.

The total area of wall in comparison to the total area of openings on an elevation.

- more terms found in the Glossary, p. 96

Changes requiring a COA

Examples:

- * Removing and replacing windows.
- * Closing existing window openings.
- * Adding new window opening.
- * Adding new storm windows.

Changes not requiring a COA

Examples:

- * Replacing broken window glass.
- * Repairing damaged portions of existing window sashes.
- * Weatherstripping, caulking, painting and other general maintenance.

Common Mistakes

- ▶ Replacing deteriorated but repairable historic windows with new windows, even similar looking windows. [A]
- ▶ Replacing damaged windows with stock windows of a different size, design, or with flat muntins. [A], [B], [E]
- ▶ Using vinyl or aluminum replacement windows. [C]
- ▶ Adding or removing windows on the facade. [D]
- ▶ Adding shutters which do not fit the window or adding shutters to paired windows. [C]
- ▶ Adding storm windows of “raw” aluminum or which hide the historic window. [D]

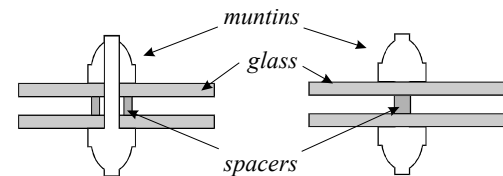
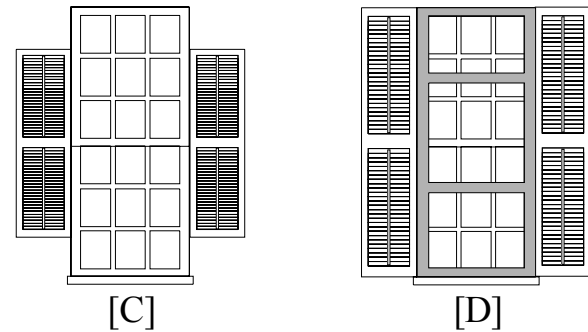
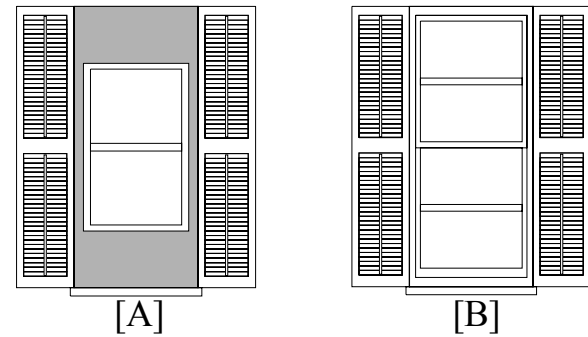

Use actual divided lights (ADLs), shown left, or simulated divided lights (SDLs), shown right, when replacing windows; **NOT** single light windows with grilles, shown below.



GOAL:

The primary goal is to maintain historic doors, their design, and their placement.

Actions to achieve the goal:

- ▶ Maintain and preserve historic doors.
- ▶ Repair damaged portions of doors rather than replacing them in total.
- ▶ Doors damaged beyond repair should be replaced with doors of matching materials and design.
- ▶ Maintain the door arrangement on the facade.
- ▶ New doors on side and rear elevations should relate to historic doors in the following ways:
 - a) use matching materials,
 - b) be of matching or similar size, and
 - c) use matching or similar design.
- ▶ Use storm doors which match the color of the door frame and hide the door as little as possible.

Replace only deteriorated sections rather than the entire door.

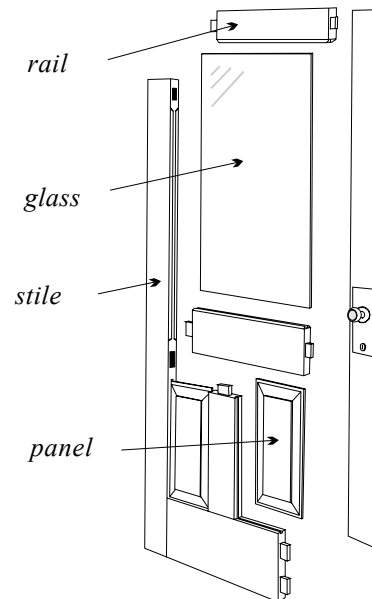

Doors refers to entrances into the building including the doorway and surrounding features such as sidelights and transoms.

Glossary terms:

Beyond repair.

When such a large portion of an element is damaged that repair becomes infeasible, generally, but not specifically, more than 50%.

Facade.

The front elevation or “face” of a building.

Fanlight.

An semicircular or semi-elliptical window with radiating muntins suggesting a fan.

French door.

A door made of many glass panes, usually used in pairs and attached by hinges to the sides of the opening in which it stands.

Mullion. A heavy vertical divider between windows or doors.

Pediment.

A triangular crowning element forming the gable of a roof; any similar triangular element used over windows, doors, etc.

Surround.

An encircling border or decorative frame, usually around a window or door.

Transom.

A small operable or fixed window located above a window or door.

- more terms found in the Glossary, p. 96

Changes requiring a COA

Examples:

- * Removing and replacing doors.
- * Closing existing door openings.
- * Adding new door openings.
- * Adding new storm or screen doors.

Changes not requiring a COA

Examples:

- * Repairing damaged portions of existing doors.
- * Weatherstripping, caulking, painting and other general maintenance.

Common Mistakes

- ▶ *Replacing deteriorated but repairable historic doors with new doors, even if similar looking.*
- ▶ *Replacing damaged doors with stock doors of a different size or design.* [A]
- ▶ *Adding or removing doors on the facade.*
- ▶ *Adding sidelights, transoms, fanlights, or other features where none existed before.* [B]
- ▶ *Adding storm doors which hide the historic door.* [C]

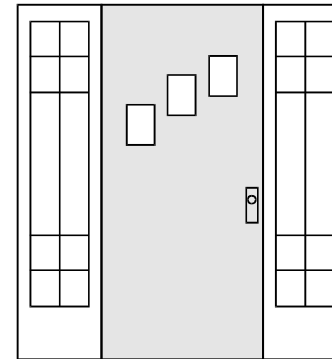

[A]

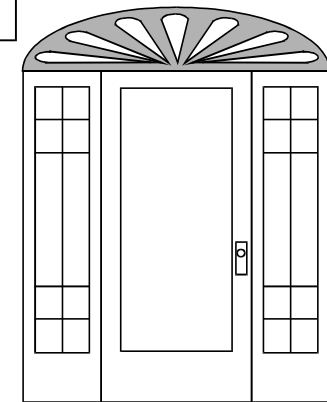

[B]

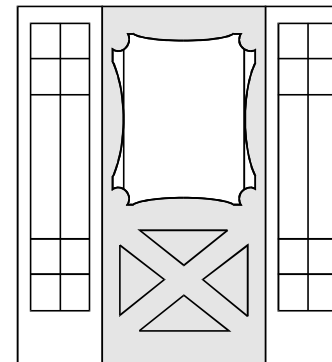

[C]

GOAL:

The primary goal is to maintain the form, design, and materials of historic porches.

Actions to achieve the goal:

- ▶ Maintain and preserve the following aspects of historic porches:
 - a) the open design,
 - b) the historic materials
 - c) the roof supports and balustrades, and
 - d) the roof shape.
- ▶ Add only elements which are documented to have existed historically.
- ▶ Screen only rear and side porches or, in very few instances, the front porches of vernacular houses.
- ▶ Set screening behind architectural details.



Porches refers open transitional spaces outside the envelope of the house, generally roofed, located on the front, rear, or sides of a house.

Glossary terms:

Bracket.

A decorative support feature located under eaves or overhangs.

Routine maintenance.

Any action performed in order to preserve a historic property including minor replacement of material with like material providing no change is made to the appearance of the structure or grounds.

Vernacular.

Indigenous architecture that generally is not designed by an architect and may be characteristic of a particular area. Any local adaptation of popular architectural forms.

- more terms found in the Glossary, p. 96

Changes requiring a COA

Examples:

- * Removing porches or portions of porches.
- * Adding a new porch. (For new decks see p. 88)
- * Enclosing, glazing, or screening a porch.
- * Adding, removing, or replacing porch posts, railings, or other porch features.
- * Reroofing a porch with a different material.

Changes not requiring a COA

Examples:

- * Repainting a porch.
- * Replacing a damaged porch floor with the same material.
- * Reroofing a porch with the same material.
- * Routine maintenance.

Common Mistakes

- ▶ *Replacing porch floor and foundation with slab concrete or brick. [A]*
- ▶ *Enclosing or glazing front porches or enclosing side porches. [B]*
- ▶ *Adding front porches to historic homes where none existed before.*
- ▶ *Screening architecturally significant front porches.*
- ▶ *Using stock “Victorian” replacement porch features that are out of scale with historic examples.*



ADDITIONS

GOAL:

The primary goal is to allow for the expansion of a house while maintaining its historic character.

Actions to achieve the goal:

- ▶ Additions should respect the original portion of the house by:
 - a) being placed away from the public view on the rear elevation or on a side elevation well behind the facade,
 - b) not obscuring the form, orientation, or symmetry of the original structure,
 - c) creating a discernible break at the juncture with the original structure,
 - d) using matching or similar materials for roofing and siding,
 - e) using matching or similar elements, such as windows, on side elevations and reserving more modern elements for the rear elevation,
 - f) not exceeding the degree of ornamentation on the original structure, and
 - g) being reversible with a limited loss of historic materials and elements.

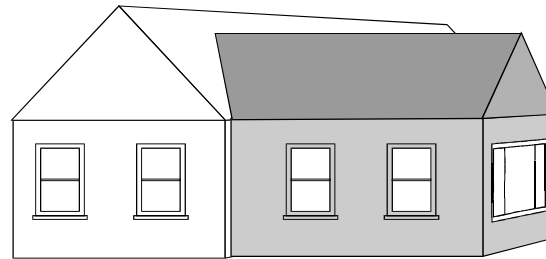
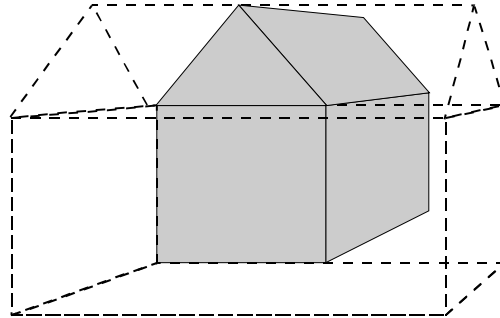

Additions refers to any increase in the square footage of a house.

Glossary terms:

Elevation.

Any of the external faces of a building.

Facade.

The front elevation or “face” of a building.

Public view.

That which can be seen from any public right-of-way.

Reversible.

Constructing additions or new elements in such a manner that if removed in the future original form and material would be largely unchanged.

Routine maintenance.

Any action performed in order to preserve a historic property including minor replacement of material with like material providing no change is made to the appearance of the structure or grounds.

Orientation.

The direction that the building (usually includes the primary entrance) faces.

- more terms found in the Glossary, p. 96

Changes requiring a COA

Examples:

- * Adding an addition to a house.
- * Removing an addition from a house.

Changes not requiring a COA

Examples:

- * Routine maintenance to existing additions.

Common Mistakes

- ▶ *Placing a side addition flush with the facade of the house. [A]*
- ▶ *Constructing an addition out of scale which greatly alters the original form or roof of the house. [B]*
- ▶ *Using incompatible materials or details on an addition.*
- ▶ *Removing a large amount of original material to add an addition.*

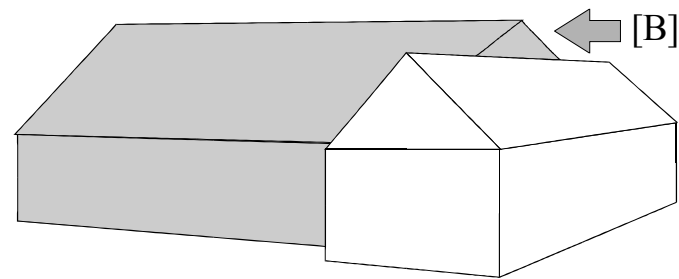
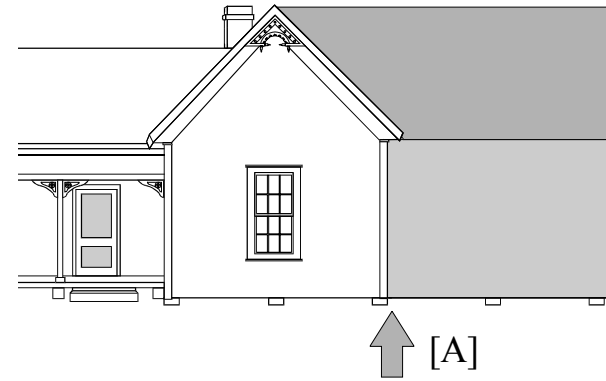

PLACEMENT

GOAL:

The primary goal is to follow the distinct rhythm established by the placement pattern of historic homes in the district.

Actions to achieve the goal:

- ▶ New buildings should respect the placement of nearby historic homes by being:
 - a) placed at a setback equal to or within 10 feet of that of nearby historic homes,
 - b) placed centrally on a lot with equal spacing on each side, and
 - c) placed oriented to or facing the same street as nearby historic homes.

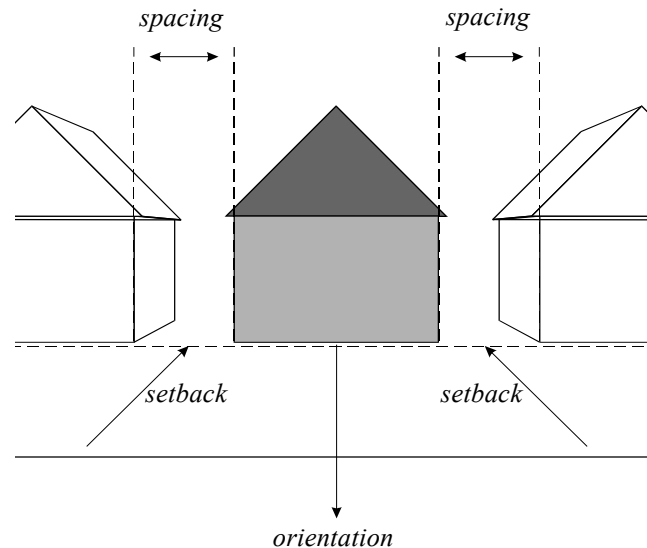

Placement refers to how the building is located or situated upon the lot. Placement includes building setback, spacing, and orientation.

Glossary terms:

Facade line.

An imaginary line established by the fronts of buildings on a block.

Nearby historic homes.

The closest possible examples: 1) adjacent historic buildings, 2) historic buildings along the same street, 3) historic buildings within the immediate area, 4) historic buildings within the district.

Orientation.

The direction that the building (usually includes the primary entrance) faces.

Rhythm.

The pattern created by the relationship of elements along a street or on individual buildings (e.g. buildings to the open space or windows to wall space).

Setback.

A term used to define the distance a building is located from a street or sidewalk.

Spacing.

The distance between adjacent buildings.

- more terms found in the Glossary, p. 96

overhead view

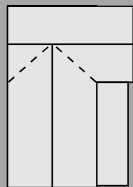
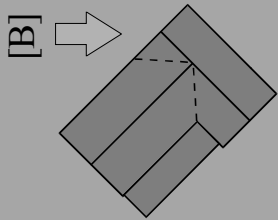
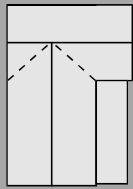
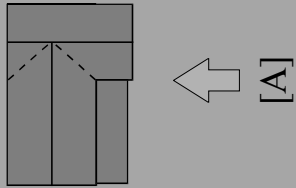

street

Common Mistakes

- ▶ *Constructing a house too deep on a lot. [A]*
- ▶ *Constructing a house diagonally on a lot. [B]*
- ▶ *Constructing a house facing a different street; corner or dual frontage properties should follow the example set by nearby corner properties.*

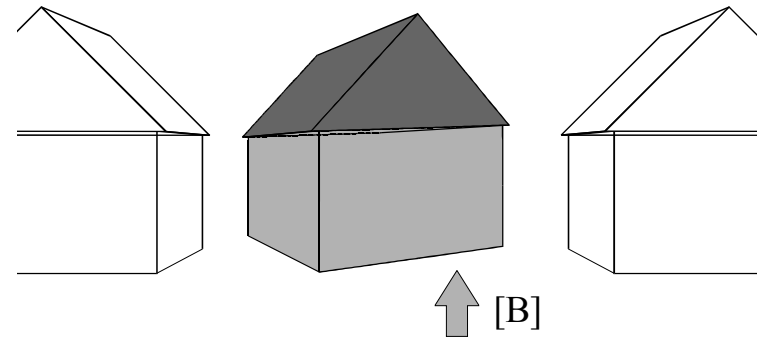
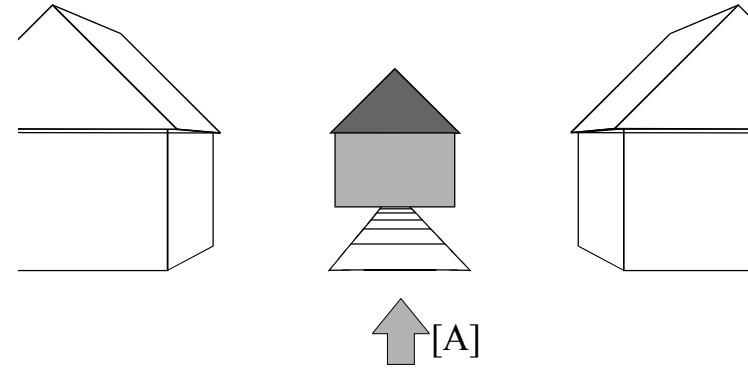

GOAL:

The primary goal is to follow the established pattern of building dimensions and forms of historic buildings within the district.

Actions to achieve the goal:

- ▶ New buildings should respect the existing scale and form of historic homes by approximately matching these aspects of nearby historic homes:
 - a) the number of stories,
 - b) the foundation, story, and roof heights,
 - c) width and depth (for more depth follow the follow traditional addition patterns),
 - d) roof shapes and pitches, and
 - e) the use of a main block and using secondary blocks; especially the use of front porches.

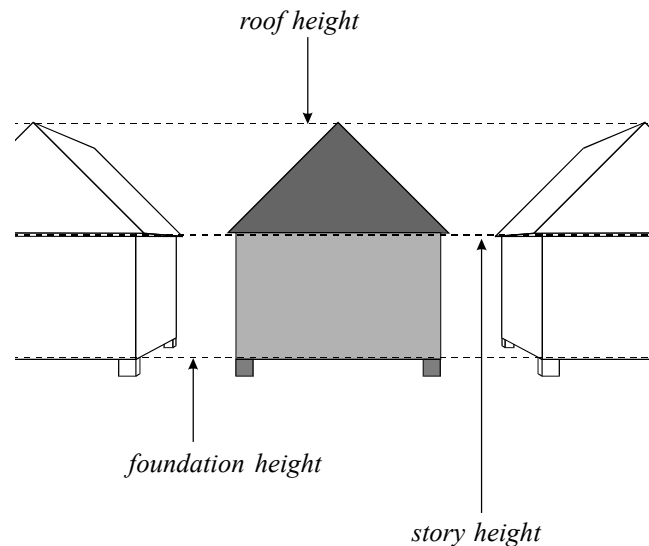

Scale refers to a building's dimensions - height, width, and depth. **Form** refers to a building's overall shape and composition.

Glossary terms:

Main block.

The central mass of a building, generally excluding secondary blocks such as additional wings, projections, dormers, or porches.

Nearby historic homes.

The closest possible examples: 1) adjacent historic buildings, 2) historic buildings along the same street, 3) historic buildings within the immediate area, 4) historic buildings within the district.

Pitch. A term which refers to the steepness of roof slope.

Secondary blocks. Portions of the building attached to the central mass of a building, generally such as additional wings, projections, dormers, or porches.

- more terms found in the Glossary, p. 96

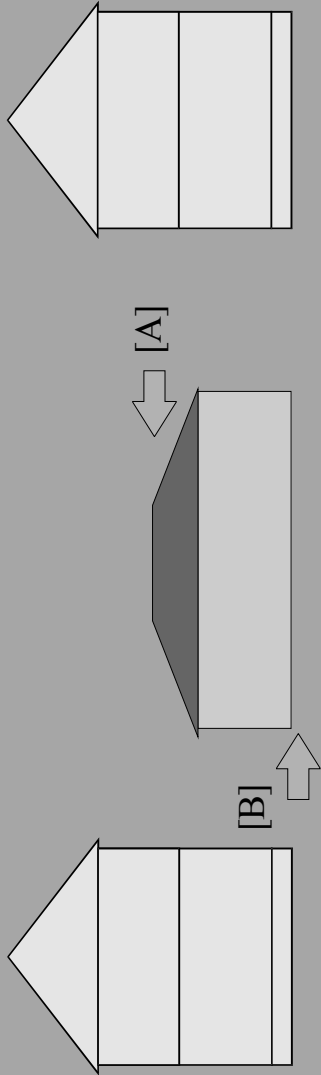

Common Mistakes

- ▶ *Constructing a one-story building along a street that has only two-story homes; the reverse scenario would also be inappropriate. [A]*
- ▶ *Constructing a building that covers almost an entire lot.*
- ▶ *Constructing a building on a slab foundation. [B]*

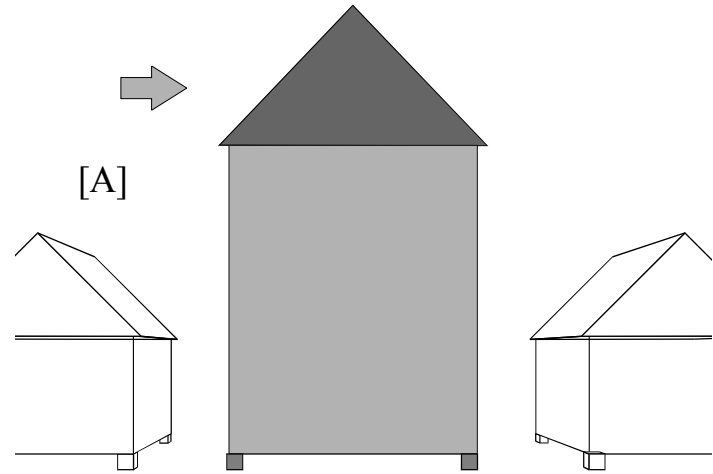

GOAL:

The primary goal is to follow the solid-to-void ratio characteristic of historic buildings in the district.

Actions to achieve the goal:

- ▶ New buildings should respect the pattern of openings on historic homes by:
 - a) using openings of similar dimensions and shape,
 - b) placing or spacing openings in a manner similar to that of nearby historic homes,
 - c) using pier foundations for front porches, and
 - d) balancing the ratio of solid-to-void by using the appropriate amount of opening on an elevation.

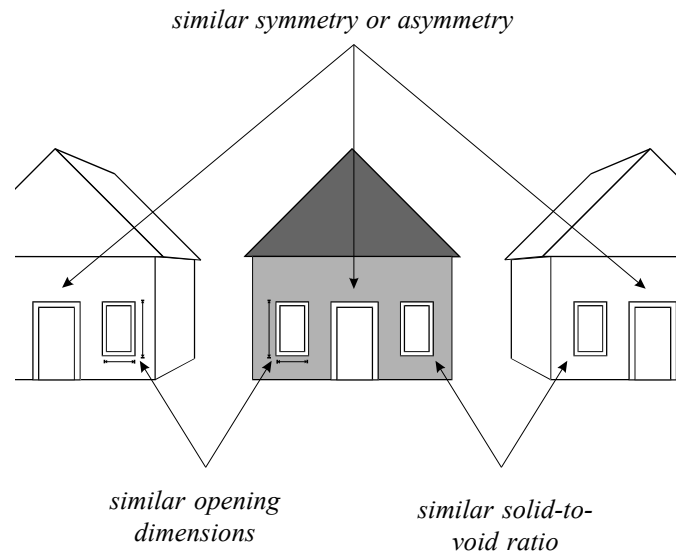

Openings refers to windows and doors. Void is another term for openings.

Glossary terms:

Elevation.

Any of the external faces of a building.

Facade.

The front elevation or "face" of a building.

Nearby historic homes.

The closest possible examples: 1) adjacent historic buildings, 2) historic buildings along the same street, 3) historic buildings within the immediate area, 4) historic buildings within the district.

Solid-to-void.

The total area of wall in comparison to the total area of openings on an elevation.

- more terms found in the Glossary, p. 96

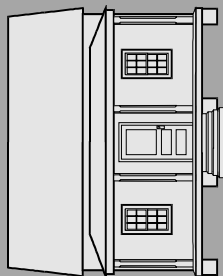
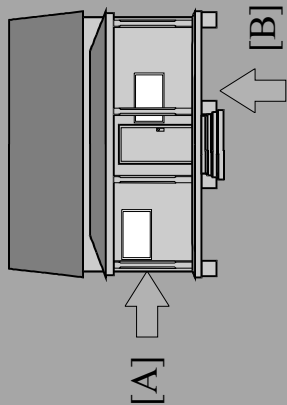
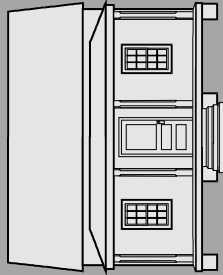

Common Mistakes

- ▶ *Using horizontal, rectangular windows on a street with vertical, rectangular windows. [A]*
- ▶ *Using an asymmetrical placement of windows and doors when symmetrical facades are the established pattern. [B]*
- ▶ *Using too many openings.*
- ▶ *Using too few openings resulting in a blank wall facade. [C]*
- ▶ *Using continuous foundations under front porches. [D]*

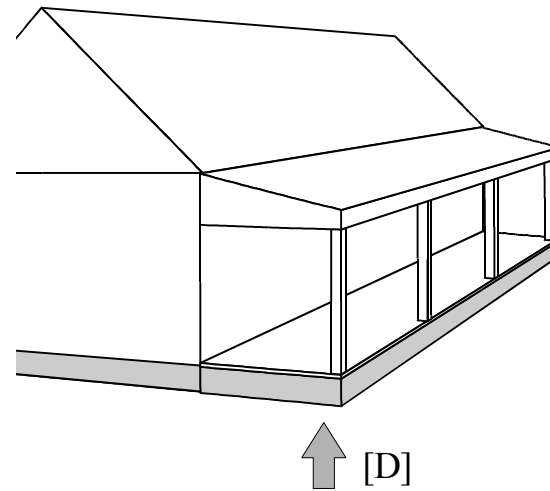
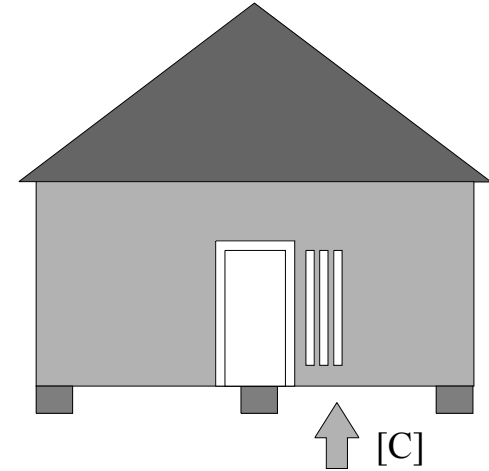

GOAL:

The primary goal is to use similar materials and a similar degree of architectural detail within the historic district.

Actions to achieve the goal:

- ▶ New buildings should respect the historic materials within the district by:
 - a) using the predominant exterior siding material - namely clapboard - or a modern material that creates a similar texture, appearance, and reveal - such as a smooth surface cementitious board like Hardiplank.
 - b) using brick and stucco to create a brick pier foundation appearance or true piers, and
 - c) using brick for chimneys.

- ▶ New buildings should respect the ornamentation within the district by using similar detail placement patterns and using details to an equal or lesser degree.

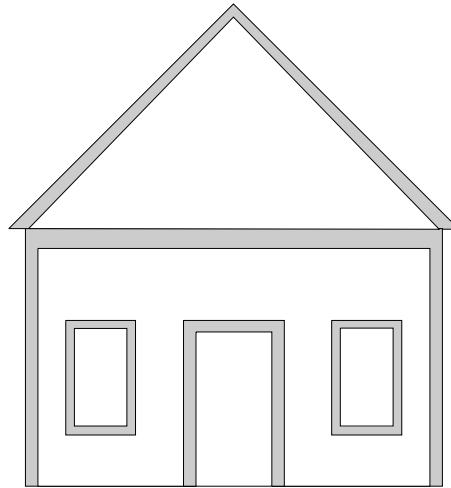

Shaded areas are traditional locations of ornament on residential buildings.

Materials and details refers to the composition, texture, and appearance of the exterior surface of a building as well as elements used to embellish the building.

Glossary terms:

Clapboard.

A wood exterior siding applied horizontally and overlapped with the lower edge thicker than the upper.

Reveal.

The vertical profile created by the lap of siding, window casings, muntins, door surrounds, etc.

Siding.

The exterior wall covering or sheathing of a structure.

Vernacular.

Indigenous architecture that generally is not designed by an architect and may be characteristic of a particular area. Any local adaptation of popular architectural forms.

- more terms found in the Glossary, p. 96

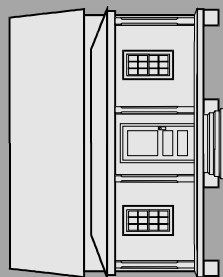
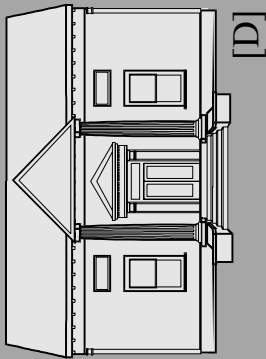
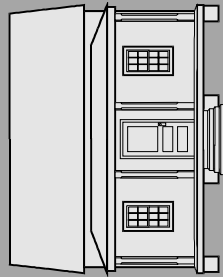

Common Mistakes

- ▶ *Using vinyl or aluminium siding.*
- ▶ *Using synthetic exterior materials with a false wood grain. [A]*
- ▶ *Using any material other than brick for chimneys. [B]*
- ▶ *Using concrete block for foundations. [C]*
- ▶ *Using too many details in a vernacular area. [D]*
- ▶ *Using stock details which do not match the proportions of historic details.*

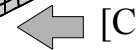
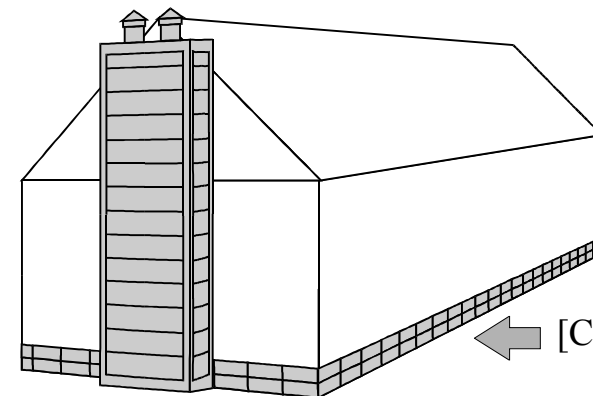
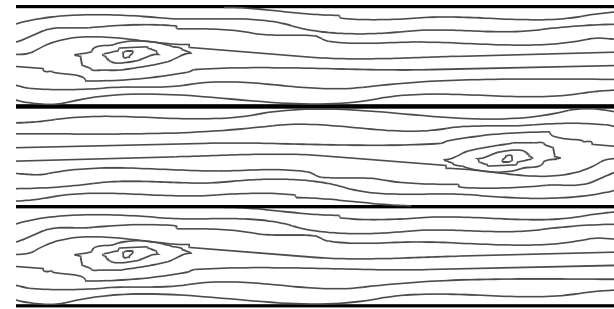

WALLS & FENCES

GOAL:

The primary goal is to maintain the pattern of open and enclosed spaces found within the historic district.

Actions to achieve the goal:

- ▶ Historic fences and retaining walls should be maintained and not removed.
- ▶ New fences and front yard retaining walls should respect the pattern within the district by:
 - a) being placed behind the facade line of the house (except retaining walls); privacy fences should be at or behind the rear elevation,
 - b) using a design appropriate to the district and the house, and
 - c) using traditional materials (in most cases wood for fences, poured concrete for retaining walls) appropriate to the district and the house.
 - d) being no taller than 36"-54" in height except privacy fences (rear yard only) which may be up to 8' tall.
- ▶ Pet enclosures of chainlink should be placed out of the public view or screened with evergreen vegetation or a traditional fence.

Fencing Locations

*Traditional and privacy fencing acceptable.
Traditional and modern retaining walls acceptable.
Pet enclosures in the public view should be screened.*

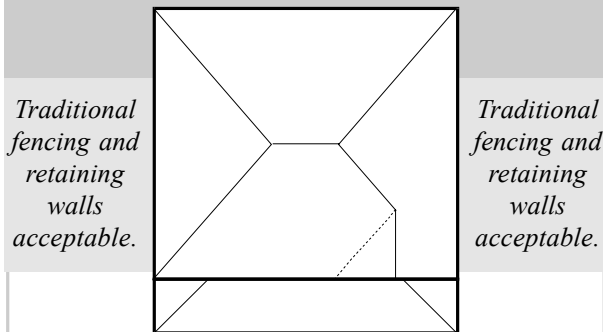

*Avoid fencing unless documented historically.
Traditional retaining walls acceptable.*

Walls and fences refers to nonvegetative elements used in and around a property for privacy, safety, security, and boundary definition.

Glossary terms:

Elevation.

Any of the external faces of a building.

Evergreen vegetation.

Vegetation which retains foliage through the winter months maintaining its screening property.

Facade line.

An imaginary line established by the fronts of buildings on a block.

Vernacular.

Indigenous architecture that generally is not designed by an architect and may be characteristic of a particular area. Any local adaptation of popular architectural forms.

- more terms found in the Glossary, p. 96

Changes requiring a COA

Examples:

- * Construction of a new fence.
- * Construction of a new retaining wall.
- * Construction of a pet enclosure.

Changes not requiring a COA

Examples:

- * Repair of an existing fence.
- * Painting an existing fence.
- * Repair of an existing retaining wall.
- * Temporary fences at construction sites.

Common Mistakes

- ▶ *Placing a fence in front of the house where none existed. [A]*
- ▶ *Using nontraditional materials such as chainlink for fences and railroad ties for front yard retaining walls. [A]*
- ▶ *Using a fence design inappropriate to the age and style of the house or district. [B]*

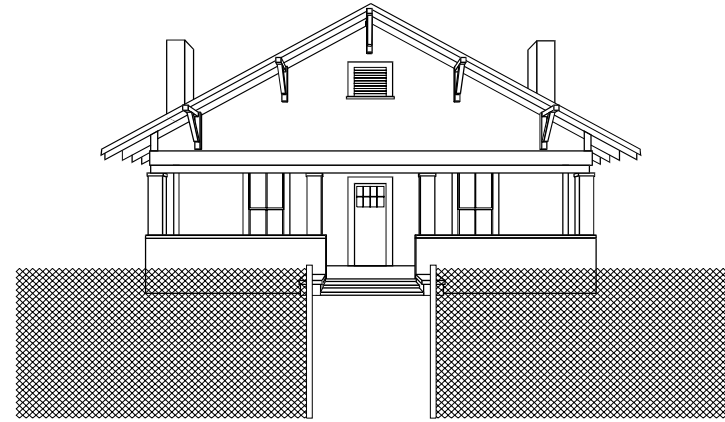

↑ [A]

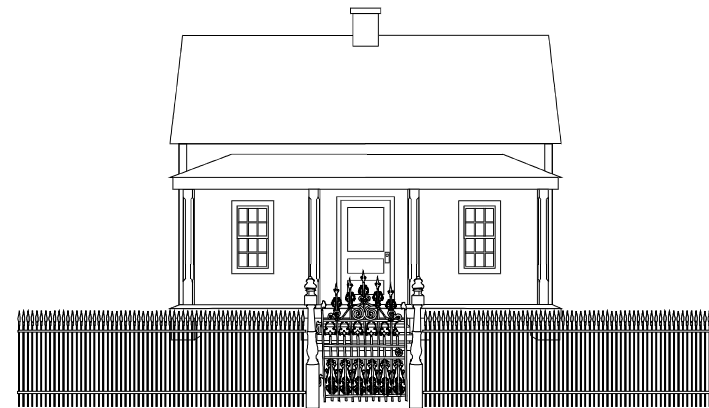

↑ [B]

WALKS & DRIVES

GOAL:

The primary goal is to maintain the pattern of paved and unpaved areas found within the historic district.

Actions to achieve the goal:

- ▶ Historic walks and drives should be maintained and preserved.
- ▶ New walks should:
 - a) use traditional placement: generally, directly from the street to the entrance for front walks, and
 - b) use traditional materials: gravel, concrete, stone pavers, and in a few instances bricks.
- ▶ New drives should:
 - a) use traditional placement: generally, straight along the side of the house, and
 - b) use traditional materials: gravel or concrete.
- Parking should be located to the rear of the house (preferred) or to the side behind the facade line of the house and screened.

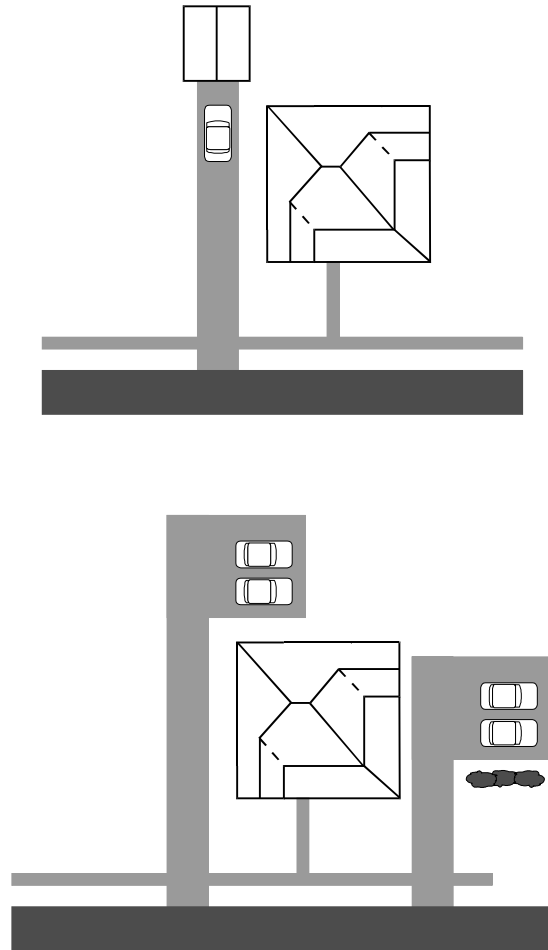

Walks and drives refers to paved pathways both to the property and within the property as well as parking areas.

Glossary terms:

Facade line.

An imaginary line established by the fronts of buildings on a block.

Paving.

Any material used for pavement such as asphalt, brick, concrete, gravel, or pavers.

- more terms found in the Glossary, p. 96

Changes requiring a COA

Examples:

- * Removing an existing walk or drive.
- * Constructing a new walk or drive.
- * Changing the paving material for and existing walk or drive.
- * Extending an existing walk or drive.
- * Adding parking areas.

Changes not requiring a COA

Examples:

- * Resurfacing an existing walk, drive or parking area with the same material.

Common Mistakes

- ▶ *Using asphalt or brick for driveways.*
- ▶ *Using circular drives where none existed historically. [A]*
- ▶ *Placing parking forward of the facade line of the house. [B]*
- ▶ *Constructing walks that lead only to the drive rather than the street or public sidewalk. [C]*

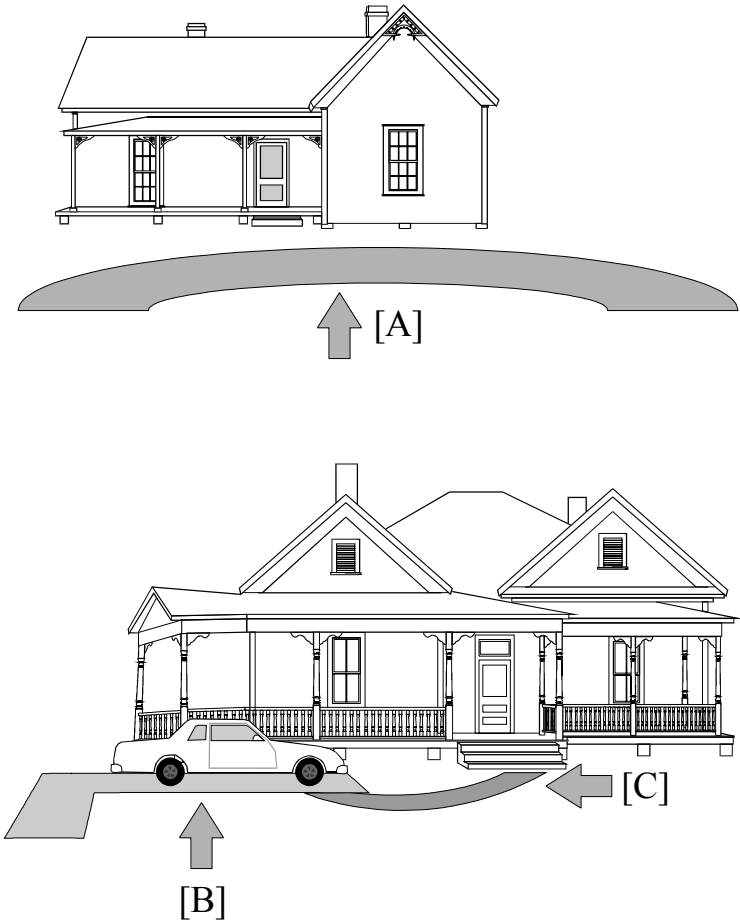

GOAL:

The primary goal is to integrate modern features while limiting the negative impact to the historic district.

Actions to achieve the goal:

- ▶ Mechanical systems and recreational structures such as pools or play equipment are best placed toward the rear of the property as unobtrusively as possible.
- ▶ Mechanical systems within the public view should be screened with evergreen vegetation or appropriate fencing.
- ▶ Modern decks should be located at the rear of the house.
- ▶ New porch and landscape lighting should:
 - a) use traditional designs appropriate to the age and character of the house, or
 - b) use modern lighting fixtures placed inconspicuously.

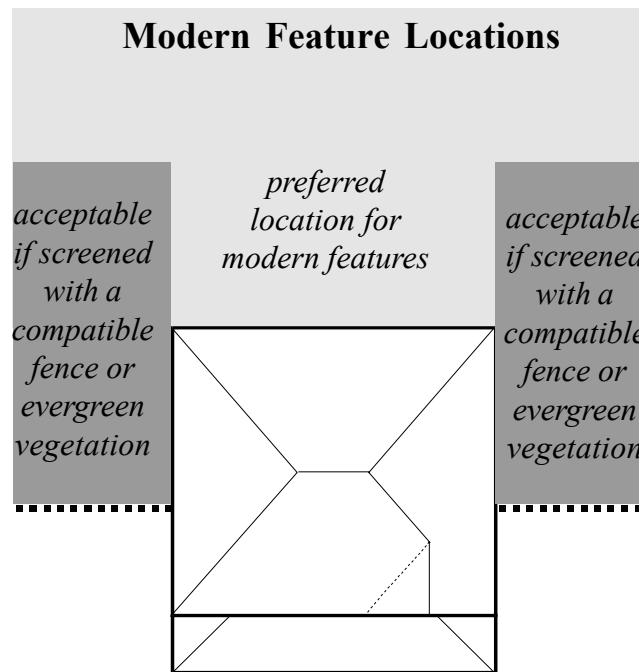

Modern features refers to mechanical systems, lighting, and recreational equipment not available in the past but now part of everyday life.

Glossary terms:

Evergreen vegetation.

Vegetation which retains foliage through the winter months maintaining its screening property.

Facade line.

An imaginary line established by the fronts of buildings on a block.

Public view.

That which can be seen from any public right-of-way.

- more terms found in the Glossary, p. 96

Changes requiring a COA

Examples:

- * Placing exterior mechanical systems such as satellite dishes or air-conditioning units.
- * Constructing a deck or pool.
- * Constructing a semipermanent play structure.
- * Adding exterior lighting including porch lights.

Changes not requiring a COA

Examples:

- * Interior changes to mechanical systems.
- * Planting vegetative screening around existing mechanical systems.
- * Temporary event lighting or tenting.
- * Placing mailboxes.

Common Mistakes

- ▶ *Placing mechanical systems or recreational equipment to the front of the property.* [A]
- ▶ *Placing a modern deck on the facade or side elevation of a house.* [B]
- ▶ *Not screening side yard placements from the public view.*
- ▶ *Using “Victorian” street lights in a residential area.* [C]
- ▶ *Using colonial carriage lamps for porch lighting.* [D]

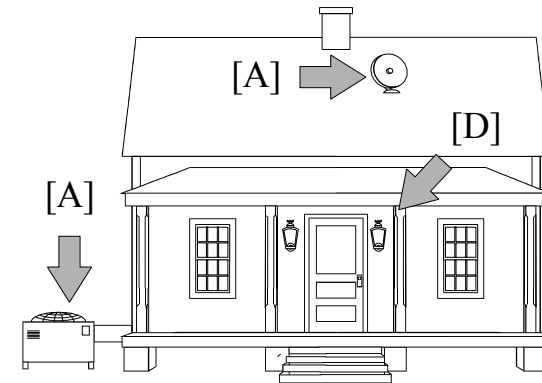
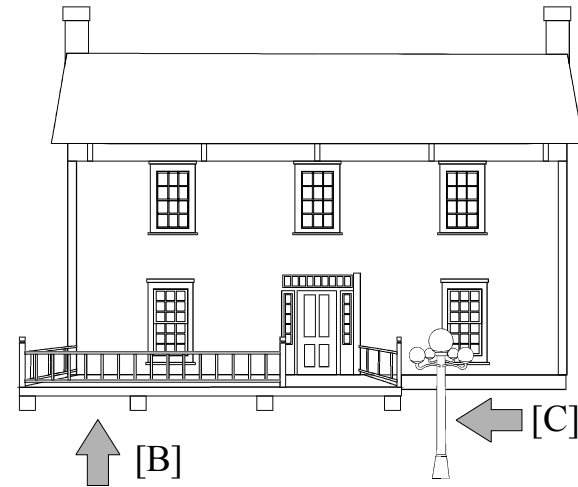

OUTBUILDINGS

GOAL:

The primary goal is to preserve historic outbuildings and to pattern new outbuildings after historic examples.

Actions to achieve the goal:

- ▶ Historic outbuildings should be preserved and maintained.
- ▶ Rehabilitation of historic outbuildings should be consistent with the rehabilitation guidelines for houses with regard to foundations, materials, details, windows, doors, and roofs.
- ▶ New outbuildings should:
 - a) use traditional placement, generally well behind the rear wall of the house,
 - b) should not be attached to the house,
 - c) should not be out of scale with the house, and
 - d) should use materials and design compatible with the house when within the public view.

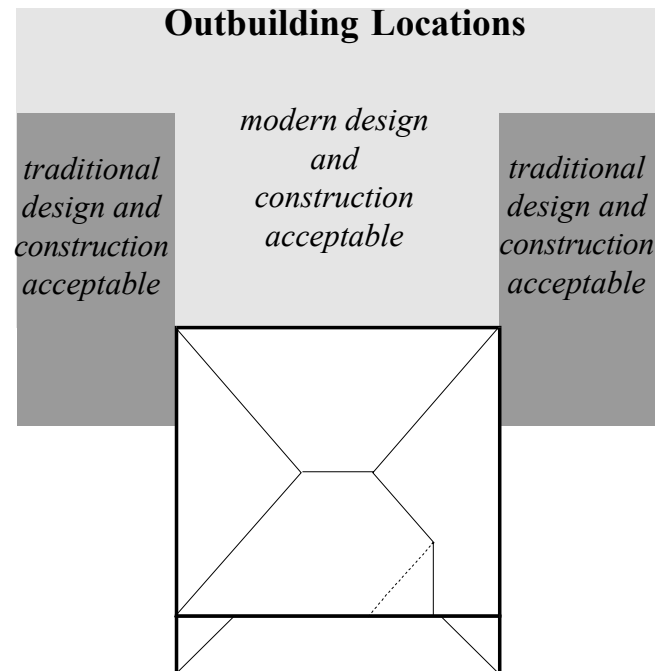

Outbuildings refers to historic and modern structures secondary to the main structure on the property.

Glossary terms:

Facade line.

An imaginary line established by the fronts of buildings on a block.

Public view.

That which can be seen from any public right-of-way.

Routine maintenance.

Any action performed in order to preserve a historic property including minor replacement of material with like material providing no change is made to the appearance of the structure or grounds.

- more terms found in the Glossary, p. 96

Changes requiring a COA

Examples:

- * Demolition of an outbuilding.
- * Construction of garage or carport.
- * Construction of a storage shed.
- * Construction of any other type of outbuilding.
- * Adding to an outbuilding.
- * Relocation of an outbuilding.

Changes not requiring a COA

Examples:

- * Painting an outbuilding.
- * Reroofing an outbuilding.
- * Routine maintenance to an outbuilding.

Common Mistakes

- ▶ *Placing outbuildings, including garages and carports, at the front of the property. [A]*
- ▶ *Attaching carports or garages to the house.*
- ▶ *Constructing outbuildings of an incompatible design when within the public view. [B]*
- ▶ *Using modern materials when the outbuilding is within the public view.*
- ▶ *Constructing outbuildings of an inappropriate scale.*

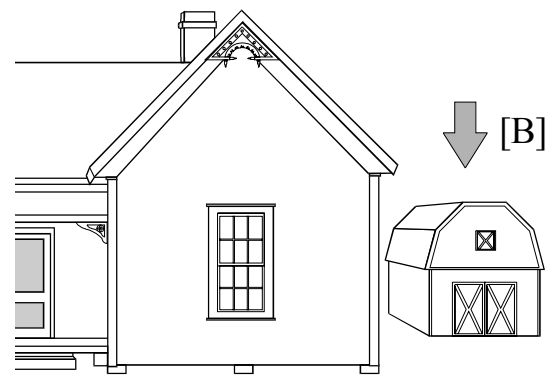
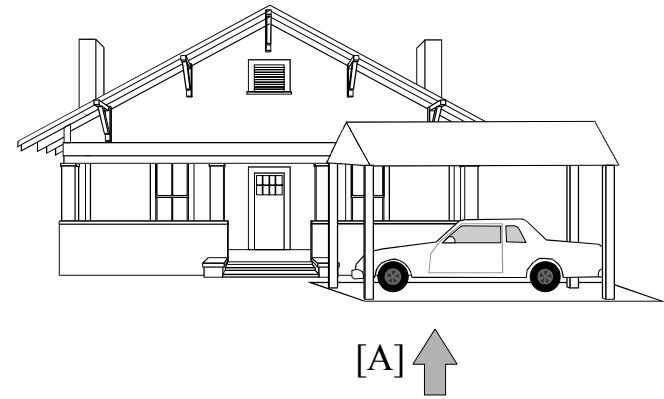

GOAL:

The primary goal is to create signs which both inform the public and compliment the property where they are located.

Actions to achieve the goal:

- ▶ Signs must conform to the City of Acworth sign ordinance.
- ▶ Signs should:
 - a) be limited one (1) sign per unit and indicate only the name of the occupant and the address number,
 - b) adhere to the prevailing design scheme of the structure and the district,
 - c) be painted wood, metal, or masonry,
 - d) be wall mounted or hanging and lighted indirectly, and
 - e) not exceed four (4) square feet in area.



Signs refers to permanent signs for home businesses, special use businesses in residential areas, or businesses in homes now zoned nonresidential.

Glossary terms:

- more terms found in the Glossary, p. 96

Changes requiring a COA

Examples:

* Placing a sign in the yard or on the building.

Changes not requiring a COA

Examples:

* Placing temporary signs such as yard sale, political, or real estate signs.

Common Mistakes

- ▶ *illuminating commercial signs in a residential sign district.*
- ▶ *Using inappropriately large signs. [B]*
- ▶ *Using signs with a colonial motif. [A]*
- ▶ *Covering architectural details such as porch railings. [B]*

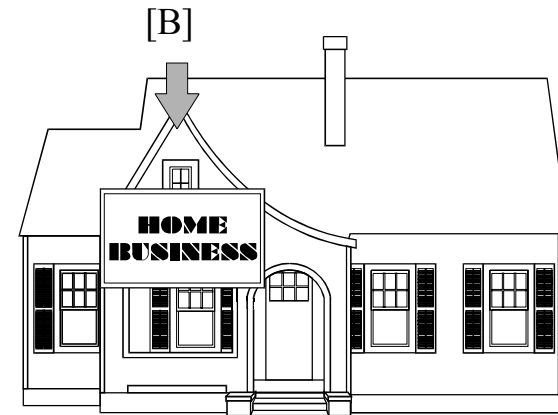

GOAL:

The primary goal is to provide barrier free access and code required egress while preserving the historic character of the building.

Actions to achieve the goal:

- ▶ Place ramps and other access aids as unobtrusively as possible while still providing convenient access to users.
- ▶ Use materials which create the least visual impact.
- ▶ Place fire escapes on side or rear elevations.
- ▶ Screen access changes with vegetation.
- ▶ Limit the removal of historic material.
- ▶ Make changes reversible.

Access Locations

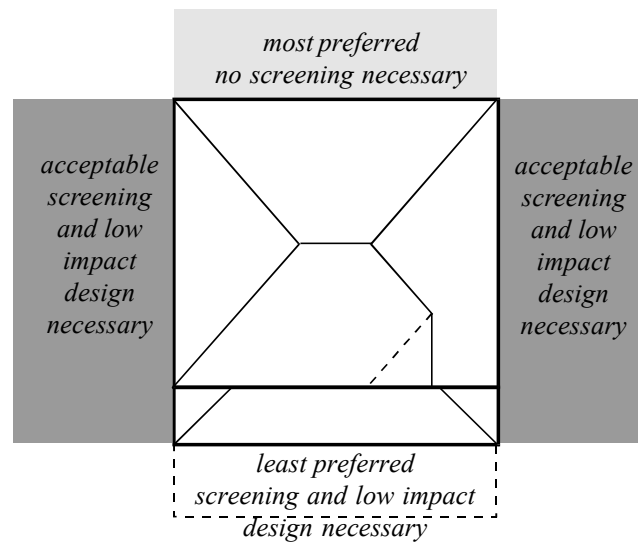

Access refers to changes required by safety codes, fire codes, the Americans with Disabilities Act, or owners' special access needs.

Glossary terms:

Barrier free access.

The provision of appropriate accommodations to ensure use of buildings by persons with disabilities.

Elevation.

Any of the external faces of a building.

Facade.

The front elevation or "face" of a building.

Public view.

That which can be seen from any public right-of-way.

Reversible.

Constructing additions or new elements in such a manner that if removed in the future original form and material would be largely unchanged.

- more terms found in the Glossary, p. 96

Changes requiring a COA

Examples:

- * Constructing a wheelchair ramp.
- * Constructing a fire escape.
- * Constructing an exterior elevator.

Changes not requiring a COA

Examples:

- * Interior modifications for accessibility.
- * Minor alterations of thresholds for accessibility.

Common Mistakes

- ▶ *Replacing or covering front steps with a ramp.* [B]
- ▶ *Adding a fire escape to the facade.* [A]
- ▶ *Altering the symmetry of a building.*
- ▶ *Not screening access features within the public view.*

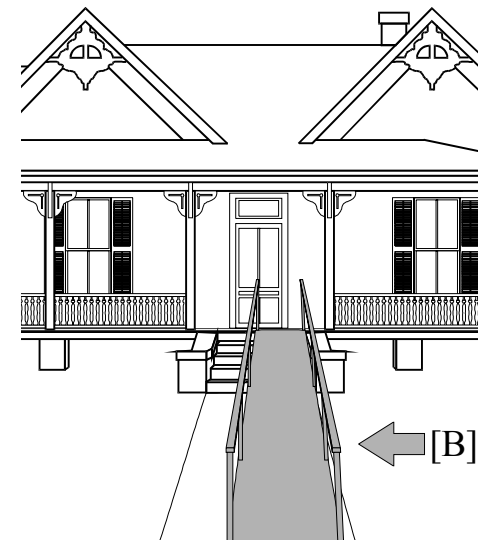
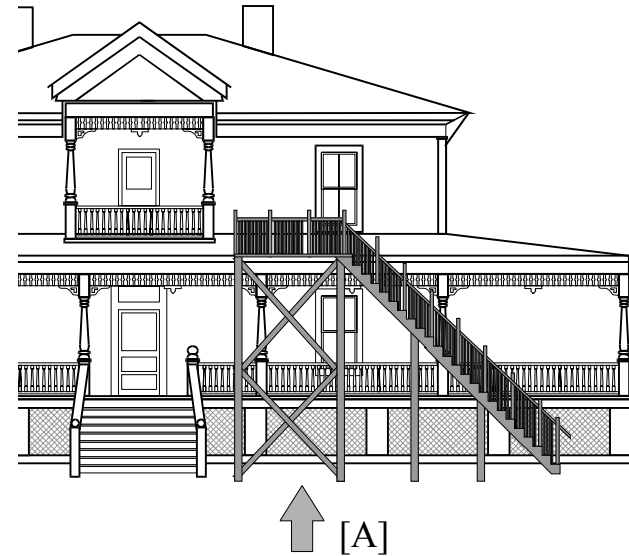

Addition. New construction added to an existing building or structure.

Alteration. Work which impacts any exterior architectural feature including construction, reconstruction, or removal of any building or building element.

Arch. A curved construction which spans an opening and supports the weight above it.

Awning. A sloped projection supported by a frame attached to the building facade or by simple metal posts anchored to the sidewalk.

Barrier free access. The provision of appropriate accommodations to ensure use of buildings by persons with disabilities.

Bay. The horizontal divisions of a building, defined by windows, columns, pilasters, etc.

Beyond repair. When such a large portion of an element is damaged that repair becomes infeasible, generally, but not specifically, more than 50%.

Bond. A term used to describe the various patterns in which brick is laid.

Bracket. A decorative support feature located under eaves or overhangs.

Bulkhead. The panel between framing members and beneath the display windows in a storefront; also known as a kickpanel or kickplate.

Canopy. A flat projection from the building facade or attached to the building facade to shelter the storefront and pedestrian traffic.

Capital. Topmost member of a column or pilaster.

Cast iron front. A storefront made of glass and pieces of utilitarian and decorative iron cast in easily assembled parts.

Character defining. An element whose design and material is associated with the age and style of a building and helps define its architectural style (e.g. tile roofing on Mission Style buildings).

Clapboard. A wood exterior siding applied horizontally and overlapped with the lower edge thicker than the upper.

Column. A vertical, cylindrical or square supporting member, usually with a classical capital.

Coping. The capping member of a wall or parapet.

Corbeling. A series of stepped or overlapped pieces of brick or stone forming a projection from the wall surface.

Cornice. The uppermost, projecting part of an entablature, or feature resembling it.

Course. A horizontal layer or row of stones or bricks in a wall.

Dentil. One of a series of small, square, tooth or block-like projections forming a molding.

Documentation. Evidence of missing elements or configurations of buildings such as architectural plans, historic photographs, or “ghosts” of missing elements.

Double hung window. A window having two sashes, one sliding vertically over the other.

Elevation. Any of the external faces of a building.

Entablature. The horizontal group of members supported by the columns, divided into three major parts, it consists of architrave, frieze, and cornice.

Evergreen vegetation. Vegetation which retains foliage through the winter months maintaining its screening property.

Facade. The front elevation or “face” of a building.

Facade line. An imaginary line established by the fronts of buildings on a block.

Fanlight. An semicircular or semi-elliptical window with radiating muntins suggesting a fan.

Fascia. A projecting flat horizontal member or molding; forms the trim of a flat roof or a pitched roof; also part of a classical entablature.

Fenestration. The arrangement of window openings in a building.

Finial. A projecting decorative element at the top of a roof, turret or gable.

Flashing. Thin metal sheets used to make the intersections of roof planes and roof/wall junctures watertight.

Footprint. The outline of a building’s ground plan from a top view.

Foundation. The lowest exposed portion of the building wall, which supports the structure above.

Frame construction. A method of construction in which the major parts consist of wood.

French door. A door made of many glass panes, usually used in pairs and attached by hinges to the sides of the opening in which it stands.

Frieze. The middle horizontal member of a classical entablature, above the architrave and below the cornice.

Gable roof. A pitched roof with one downward slope on either side of a central, horizontal ridge.

Gentlest means possible. The least abrasive, intrusive, damaging means of preserving historic material.

Historic mortar mix.

There are designated five mortar types. Typically, the repointing mortar for historic buildings will be a Type O or K mortar. Mortar specifications permit a range of proportions, but typical proportions by volume are: Type O - 1 part portland cement, 2 parts hydrated lime, and 9 parts sand; Type K - 1 part portland cement, 4 parts hydrated lime and 15 parts sand.

Hood molding. A projecting molding above an arch, doorway, or window, originally designed to direct water away from the opening; also called a drip mold.

Infill. New construction where there had been an opening before. Applies to a new structure such as a new building between two older structures or new material such as block infill in an original window opening.

In-kind. Using the exact same material when replacing a damaged element (e.g. using a wood element to replace a wood element).

Jack arch. An arch with wedge shaped stones or bricks set in a straight line; also known as a flat arch.

Jamb. The vertical side of a doorway or window.

Keystone. The top or center member of an arch.

Light. A single pane of glass.

Lintel. A horizontal beam over a door or window which carries the weight of the wall above; usually made of stone or wood.

Main block. The central mass of a building, generally excluding secondary blocks such as additional wings, projections, dormers, or porches.

Masonry. Brick, block, or stone which is secured with mortar.

Massing. A term used to define the overall volume of a building.

Modillion. A horizontal bracket, often in the form of a plain block, ornamenting, or sometimes supporting, the underside of a cornice.

Mortar. A mixture of sand, lime, cement, and water used as a binding agent in masonry construction.

Mullion. A heavy vertical divider between windows or doors.

Muntin. A secondary framing member to divide and hold the panes of glass in a window.

National Register of Historic Places. The nation's official list of buildings, sites, and districts which are important in our history or culture. Created by Congress in 1966 and administered by the states.

Nearby historic homes/buildings. The closest possible examples: 1) adjacent historic buildings, 2) historic buildings along the same street, 3) historic buildings within the immediate area, 4) historic buildings within the district.

Orientation. The direction that the building (usually includes the primary entrance) faces.

Parapet. A low protective wall located at the edge of a roof.

Parking. Areas, generally paved, provided for the storage of automobiles.

Party wall. A common, shared wall between two buildings; typical of downtown brick buildings.

Paving. Any material used for pavement such as asphalt, brick, concrete, gravel, or pavers.

Pediment. A triangular crowning element forming the gable of a roof; any similar triangular element used over windows, doors, etc.

Pier. A vertical structural element, square or rectangular in cross section.

Pilaster. A pier attached to a wall, often with capital and base.

Pitch. A term which refers to the steepness of roof slope.

Portico. A roofed space, open or partly enclosed, forming the entrance and centerpiece of the facade of a building, often with columns and a pediment.

Portland cement. A strong, inflexible (too much so for historic buildings) hydraulic cement used to bind mortar.

Proper repointing. Hand raking deteriorated mortar and duplicating old mortar in strength, composition, color, and texture as well as joint width and joint profile.

Public view. That which can be seen from any public right-of-way.

Quoins. Decorative blocks of stone or wood used on the corners of buildings.

Recessed panel. A decorative element that often functions as an area for signage.

Reveal. The vertical profile created by the lap of siding, window casings, muntins, door surrounds, etc.

Reversible. Constructing additions or new elements in such a manner that if removed in the future original form and material would be largely unchanged.

Routine maintenance. Any action performed in order to preserve a historic property including minor replacement of material with like material providing no change is made to the appearance of the structure or grounds.

Rhythm. The pattern created by the relationship of elements along a street or on individual buildings (e.g. buildings to the open space or windows to wall space).

Sash. The portion of a window that holds the glass and which moves.

Scale. A term used to define the proportions of a building in relation to its surroundings.

Secondary blocks. Portions of the building attached to the central mass of a building, generally such as additional wings, projections, dormers, or porches.

Setback. A term used to define the distance a building is located from a street or sidewalk.

Sidelight. A glass window pane located at the side of a main entrance way.

Siding. The exterior wall covering or sheathing of a structure.

Sill. The horizontal member located at the top of a foundation supporting the structure above; also the horizontal member at the bottom of a window or door.

Solid-to-void. The total area of wall in comparison to the total area of openings on an elevation.

Spacing. The distance between adjacent buildings.

Storefront. The street-level facade of a commercial building, usually having display windows.

Streetscape. The combination of building facades, sidewalks, street furniture, etc. that define the street.

Stucco. Any kind of plasterwork, but usually an outside covering of portland cement, lime, and sand mixture with water.

Surround. An encircling border or decorative frame, usually around a window or door.

Synthetic stucco (EIFS). Exterior insulation and finish systems (EIFS) are multi-component exterior wall systems which generally consist of: an insulation board; a base coat reinforced with glass fiber mesh; and a finish coat.

Transom. A small operable or fixed window located above a window or door.

Variegated brick. Multi-colored brick used in an attempt to create an antique look.

Vernacular. Indigenous architecture that generally is not designed by an architect and may be characteristic of a particular area. Any local adaptation of popular architectural forms.

Wrought iron. Decorative iron that is hammered or forged into shape by hand, as opposed to cast iron which is formed in a mold.